



U.S. Department
of Transportation

Pipeline and
Hazardous Materials
Safety Administration

East Building, PHH-23
1200 New Jersey Ave, SE
Washington, D.C. 20590

**COMPETENT AUTHORITY CERTIFICATION FOR A
NON-FISSILE OR FISSILE EXCEPTED
URANIUM HEXAFLUORIDE PACKAGE DESIGN
CERTIFICATE USA/0681/H(U)-96, REVISION 7**

**REVALIDATION OF UNITED KINGDOM COMPETENT AUTHORITY
CERTIFICATE GB/3572/H(U)-96**

The Competent Authority of the United States certifies that the radioactive material package design described in this certificate satisfies the regulatory requirements for a H(U) package for non fissile or fissile excepted quantities of uranium hexafluoride as prescribed in the regulations of the International Atomic Energy Agency¹ and the United States of America² The package design is approved for use within the United States for import and export shipments made in accordance with applicable international and domestic transport regulations.

1. Package Identification - 48X or 48Y cylinder with residual (heel) quantity of uranium hexafluoride.
2. Package Description - 48X or 48Y cylinders as described in United Kingdom Certificate of Competent Authority No. GB/3572/H(U)-96, Rev 7, subject to the special conditions listed in Section 5 of this certificate.
3. Authorized Contents - Residual quantities of solid, non fissile or fissile excepted uranium hexafluoride as described in United Kingdom Certificate of Competent Authority No. GB/3572/H(U)-96, Rev 7, and the special conditions listed in Section 5 of this certificate.
4. General Conditions -
 - a. Each user of this certificate must have in his possession a copy of this certificate and all documents necessary to properly prepare the package for transportation. The user shall prepare the package for shipment in accordance with the documentation and applicable regulations.

¹ "Regulations for the Safe Transport of Radioactive Material, 2012 Edition, No. SSR-6" published by the International Atomic Energy Agency (IAEA), Vienna, Austria.

² Title 49, Code of Federal Regulations, Parts 100-199, United States of America.

CERTIFICATE USA/0681/H(U)-96, REVISION 7

- b. Each user of this certificate, other than the original petitioner, shall register his identity in writing to the Office of Engineering and Research, (PHH-23), Pipeline and Hazardous Materials Safety Administration, U.S. Department of Transportation, Washington D.C. 20590-0001.
- c. This certificate does not relieve any consignor or carrier from compliance with any requirement of the Government of any country through or into which the package is to be transported.
- d. Records of Management System activities required by Paragraph 306 of the IAEA regulations¹ shall be maintained and made available to the authorized officials for at least three years after the last shipment authorized by this certificate. Consignors in the United States exporting shipments under this certificate shall satisfy the applicable requirements of Subpart H of 10 CFR 71.

5. Special Conditions -

- a. Cylinders transported under this certificate must have been designed and manufactured in accordance with the ANSI N14.1 standard in effect at the time of manufacture.
- b. Cylinders transported under this certificate must be operated and maintained in accordance the the ANSI N14.1 standard in effect at the time of shipment.
- c. Cylinders transported under this certificate must contain a quantity of uranium hexafluoride which is compliant with both Title 49 of U.S. Code of Federal Regulations and the ANSI N14.1 standard in effect a the time of shipment.

6. Marking and Labeling - The package shall bear the marking USA/0681/H(U)-96 in addition to other required markings and labeling.

7. Expiration Date - This certificate expires on July 31, 2025. Previous editions which have not reached their expiration date may continue to be used.

CERTIFICATE USA/0681/H(U)-96, REVISION 7

This certificate is issued in accordance with paragraph(s) 805 of the IAEA Regulations and Section 173.477 of Title 49 of the Code of Federal Regulations, in response to the May 15, 2020 petition by Honeywell, Metropolis, IL, and in consideration of other information on file in this Office.

Certified By:



June 18, 2020

(DATE)

 William Schoonover
Associate Administrator for Hazardous
Materials Safety

Revision 7 - Issued to endorse United Kingdom Certificate of Approval No. GB/3572/H(U)-96, Rev 7, for ANSI N14.1 compliant cylinders.



CERTIFICATE OF APPROVAL OF PACKAGE DESIGN FOR THE CARRIAGE OF RADIOACTIVE MATERIAL

This is to certify that for the purposes of the Regulations of the International Atomic Energy Agency

- The Competent Authority of Great Britain in respect of inland surface transport, being the Office for Nuclear Regulation;
- The Competent Authority of the United Kingdom of Great Britain and Northern Ireland in respect of sea transport, being the Secretary of State for Transport;
- The Competent Authority of the United Kingdom of Great Britain and Northern Ireland in respect of air transport, being the Civil Aviation Authority; and
- The Competent Authority of Northern Ireland in respect of road transport, being the Department of Agriculture, Environment and Rural Affairs - Northern Ireland

approve the package design specified in Section 1 of this certificate, as submitted for approval by URENCO UK Ltd (see Section 5)

as: Type H(U)

by: road and rail in Great Britain, and sea.

Packaging identification: 48X or 48Y uranium hexafluoride cylinders without thermal protection

Packages manufactured to this design meet the requirements of the regulations and codes on page 2, relevant to the mode of transport, subject to the following general condition and to the conditions in the succeeding pages of this certificate.

In the event of any alteration in the composition of the package, the package design, the management system(s) associated with the package or in any of the facts stated in the application for approval, this certificate will cease to have effect unless the Competent Authority is notified of the alteration and the Competent Authority confirms the certificate notwithstanding the alteration.

Expiry Date: This certificate is valid from 01 August 2020 until 31 July 2025 (see Section 5).

COMPETENT AUTHORITY IDENTIFICATION MARK: GB/3572/H(U)-96

Signature:

Date of Issue: 12 May 2020

Gavin Smith, Superintending Inspector
Office for Nuclear Regulation
Redgrave Court, Merton Road
Bootle, Merseyside
L20 7HS

on behalf of the Office for Nuclear Regulation; the Secretary of State for Transport; the Civil Aviation Authority; and the Department of Agriculture, Environment and Rural Affairs - Northern Ireland.

This certificate does not relieve the consignor from compliance with any requirement of the government of any country through or into which the package will be transported.

REGULATIONS GOVERNING THE TRANSPORT OF RADIOACTIVE MATERIALS

INTERNATIONAL

International Atomic Energy Agency (IAEA)

SSR-6 Regulations for the Safe Transport of Radioactive Material 2012 Edition

United Nations Economic Commission for Europe (UNECE)

European Agreement concerning the International Carriage of Dangerous Goods by Road (ADR) 2019 Edition

Intergovernmental Organisation for International Carriage by Rail (OTIF)

Regulations concerning the International Carriage of Dangerous Goods by Rail (RID) 2019 Edition

International Maritime Organization (IMO)

International Maritime Dangerous Goods (IMDG) Code 2018 Edition incorporating Amendment 39-18

International Civil Aviation Organization (ICAO)

Technical Instructions for the Safe Transport of Dangerous Goods by Air 2019-2020 Edition

UNITED KINGDOM

ROAD

GREAT BRITAIN ONLY:

The Energy Act 2013 (2013 c. 32); The Carriage of Dangerous Goods and Use of Transportable Pressure Equipment Regulations 2009 (SI 2009 No. 1348); The Energy Act 2013 (Office for Nuclear Regulation) (Consequential Amendments, Transitional Provisions and Savings) Order 2014 (SI 2014 No. 469)

NORTHERN IRELAND ONLY:

The Carriage of Dangerous Goods and Use of Transportable Pressure Equipment Regulations (Northern Ireland) 2010, (SR 2010 No 160)

RAIL

GREAT BRITAIN ONLY:

The Energy Act 2013 (2013 c. 32); The Carriage of Dangerous Goods and Use of Transportable Pressure Equipment Regulations 2009 (SI 2009 No. 1348); The Energy Act 2013 (Office for Nuclear Regulation) (Consequential Amendments, Transitional Provisions and Savings) Order 2014 (SI 2014 No. 469)

SEA

British registered ships and all other ships whilst in United Kingdom territorial waters:

The Merchant Shipping Act 1995 (1995 c. 21); The Merchant Shipping (Dangerous Goods and Marine Pollutants) Regulations 1997 (SI 1997 No. 2367); Merchant Shipping Notice MSN 1893 (M) The Carriage of Dangerous Goods and Marine Pollutants in Packaged Form: Amendment 39-18 to the International Maritime Dangerous Goods (IMDG) Code

AIR

The Air Navigation Order 2016 (SI 2016 No. 765); The Air Navigation (Dangerous Goods) Regulations 2002 (SI 2002 No.2786)

1. DESIGN SPECIFICATION

Package Design

1.1 The package design specification shall be in accordance with URENCO UK Ltd report UUK6144487 'Safety Analysis Report In Support of Competent Authority Approval for Model 48X and 48Y Cylinder Package Design to Transport Uranium Hexafluoride' Revision 9, dated 26 June 2019.

Design Drawings

1.2 The design is specified in the following drawings.

Design No.	Title (number of components)	Drawing / Drawing List	Issue
3572	48X or 48Y Cylinder (one) with valve protector or valve protector alternate (VPA)	ANSI N14.1 Figures 11 or 12, 13	2019
		ISO7195 Figure 11 or 13	2005

Package Description and Materials of Manufacture

1.3 The packaging consists of either a Model 48X or 48Y 48" diameter steel cylinder and valve protection (either 'valve protector' or VPA 'valve protector alternate' VPA). See Appendix 1 for package illustration.

Package Dimension and Weights

1.4 Nominal dimensions:

- a) 48X – 1219mm diameter x 2940mm long
- b) 48Y – 1219mm diameter x 3727mm long

1.5 Nominal gross weight:

- a) 48X – 2174kg
- b) 48Y – 2529kg

Authorised Contents

1.6 The authorised radioactive contents are solid, depleted, natural or re-processed (U-232 maximum concentration 0.005µg/gU), non-fissile or fissile excepted, uranium hexafluoride.

1.7 The quantity shall be limited as specified in the following table:

Cylinder Type	Maximum Residual Quantity (kg UF6)
48X (with VPA)	121.7
48Y (with VPA)	159.4
48X / 48Y (with VPA or valve protector)	22.7 (heel)

Containment System

1.8 The containment system is composed of the cylinder outer shell, valve and plug.

2. USE OF PACKAGE

Information Provided in Safety Report on Use of Packaging

- 2.1 The 48X and 48Y packages shall be used, handled and maintained in accordance with ANSI N14.1 or ISO7195 and Appendix U 'Operating and Maintenance Instruction for 48Y and 48X Cylinders' Revision 1, dated July 2015, of the Package Design Safety Report referred to in Section 1 of this certificate.

Actions Prior to Shipment

- 2.2 Administrative controls shall ensure that the contents are in accordance with the safety report specified in Section 1 of this certificate and that the consignor and consignee hold a copy of the instructions on the use of the packaging.
- 2.3 Pre-shipment measurements may be taken to confirm that the maximum surface dose rate of empty / heeled cylinders are within the regulatory limit.

Emergency Arrangements

- 2.4 Before shipment takes place, suitable emergency plans will have been drawn up, copies of which shall be supplied to the GB Competent Authority on demand.
- 2.5 Within Great Britain, if the consignor's own, or other approved emergency plans, cannot be initiated for any reason, then the police shall be informed immediately.

Requirements of IAEA SSR-6 Paragraph 634

- 2.6 None of the prescriptions of the IAEA SSR-6 2012 Edition paragraph 634 apply.

3. MANAGEMENT SYSTEMS

- 3.1 The management system(s) assessed as adequate in relation to this design by the authorities named on page 1 of this certificate, at the date of issue, comprise the following:
- UUK/6154263 Issue 7.1, "UUK Integrated Management Prospectus", 14 February 2020.
- 3.2 No alteration may be made to any management system confirmed as adequate in relation to this design, unless:
- a) the authorities named on page 1 of this certificate have confirmed the amended management system is adequate prior to implementation or use; or
 - b) the alteration falls within the agreed change control procedures set out in the management system(s).
- 3.3 Other management systems for design, testing, manufacture, documentation, use, maintenance, inspection, transport and in-transit storage operations may be used providing they comply with international, national or other standards for management systems agreed as acceptable by the authorities named on page 1 of this certificate.

4. ADMINISTRATIVE INFORMATION

Related Approvals

- 4.1 Not applicable.

Shipment Approval

- 4.2 Not applicable.

Packaging Serial Numbers

- 4.3 Not applicable.

5. CERTIFICATE STATUS

Design approval issued to:

URENCO UK Ltd
Capenhurst
Chester
CH1 6ER
UK

Issue / Revision Number	Date of Issue	Date of Expiry	Reason for Revision
Issue 1	28 May 2004	31 May 2007	New approval
Issue 2	23 December 2004	31 May 2007	DSR raised to issue 4
Issue 3	19 March 2009	31 March 2014	Renewal of certificate
Issue 4	20 May 2014	31 May 2015	Renewal based on BNFL Report No. 111 Issue 4
Issue 5	24 June 2014	30 June 2015	Revised to allow use of lifting lugs
Issue 6	27 July 2015	31 July 2020	Renewal based on INS Transport Report No. 111 Revision 8
Rev 7	1 August 2020	31 July 2025	Renewal based on URENCO UK Ltd report UUK6144487 Revision 9

APPENDIX 1 – PACKAGE ILLUSTRATION

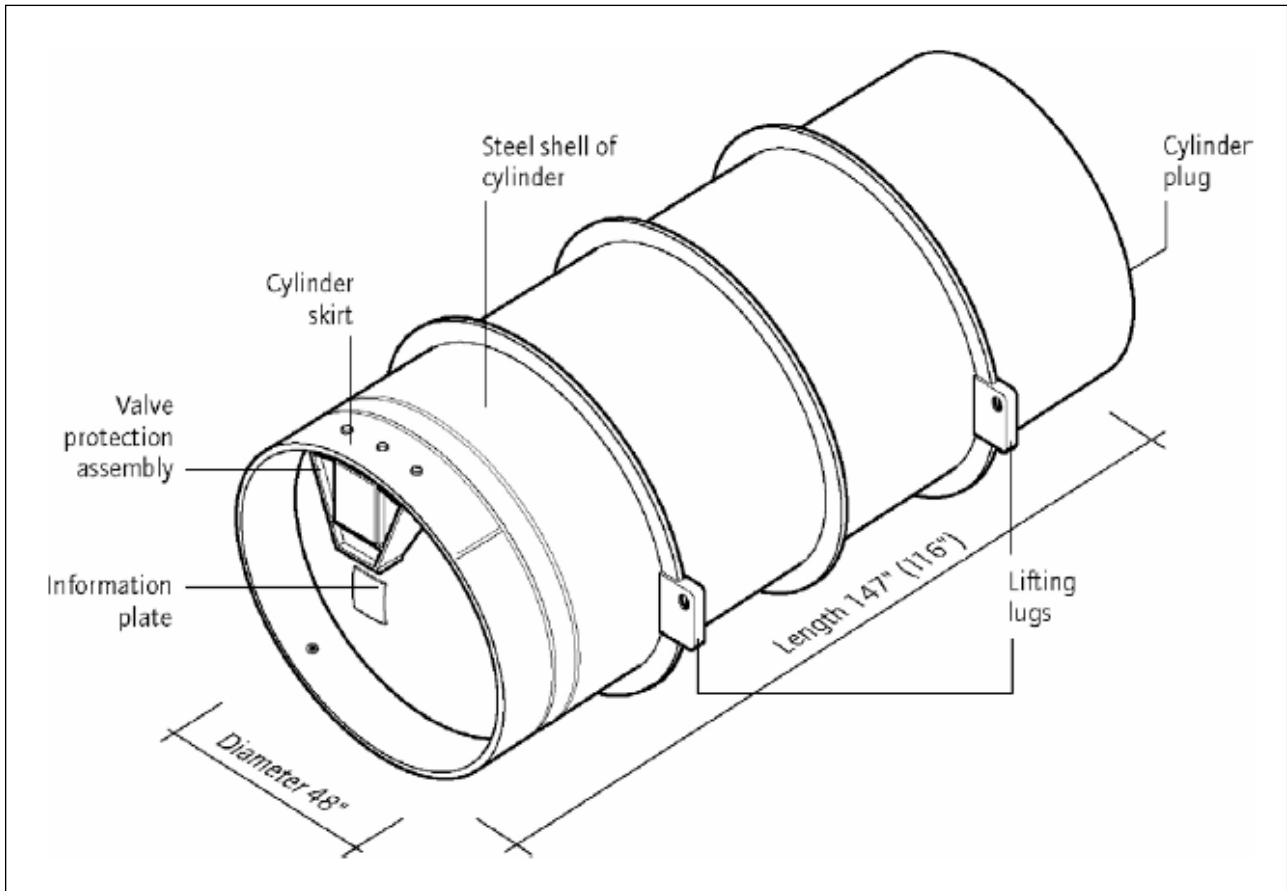

48Y (48X) UF₆ Cylinder (bare) (all dimensions are approximate)



U.S. Department of
Transportation

**Pipeline and
Hazardous Materials
Safety Administration**

East Building, PHH-23
1200 New Jersey Ave, SE
Washington, D.C. 20590

CERTIFICATE NUMBER: USA/0681/H(U)-96

ORIGINAL REGISTRANT(S) :

Edlow International Company
1666 Connecticut Ave, N.W
Suite 201
Washington, DC, 20009
USA

Global Nuclear Fuels - Americas
3901 Castle Hayne Road
Mail Code K-84
Wilmington, NC, 28401
USA

Transport Logistics International (DAHER - TLI)
8161 Maple Lawn Boulevard
Suite 480
Fulton, MD, 20759
USA

Urenco
Bahnhofstrasse 8
Bad Bentheim, Bad Bentheim, 48455
GERMANY

Cameco
205 Peter Street
Port Hope, Ontario, L1A 3V6
CANADA

Honeywell
PMT Fluorine Products
Route 45 North
P.O. Box 430
Metropolis, IL, 62960
USA

Areva - TN International

Site du Tricastin
BP16
F-26701 Pierrelatte Cedex
Tricastin, Drôme and Vaucluse,
FRANCE

Louisiana Energy Services, Urenco USA
UUSA
P.O. Box 1789
Eunice, NM, 88231
USA

International Nuclear Services Ltd
Hinton House
Risley
Warrington, Cheshire, WA3 6GR
UK

TAM International Inc.
TAM International (US) Inc.
819 Broadway Street
Paducah, KY, 42001
USA

TN Americas LLC
7135 Minstrel Way, Suite 300
Columbia, MD, 21045
USA

Framatome
2101 Horn Rapids Road
Richland, WA, 99354
USA