



U.S. Department  
of Transportation

Pipeline and  
Hazardous Materials  
Safety Administration

East Building, PHH-23  
1200 New Jersey Ave, SE  
Washington, D.C. 20590

IAEA CERTIFICATE OF COMPETENT AUTHORITY  
SPECIAL FORM RADIOACTIVE MATERIALS

CERTIFICATE USA/0758/S-96, REVISION 3

This certifies that the source described has been demonstrated to meet the regulatory requirements for special form radioactive material as prescribed in the regulations of the International Atomic Energy Agency<sup>1</sup> and the United States of America<sup>2</sup> for the transport of radioactive material.

1. Source Identification - QSA Global, Inc. Model X9073.
2. Source Description - Cylindrical single encapsulation made of MP35N and tungsten inert gas or laser seal welded. Approximate outer dimensions are 12.8 mm (0.5 in.) in diameter and 28.0 mm (1.1 in.) in length. Construction shall be in accordance with attached QSA Global, Inc. Drawing No. RBA62948, Rev. A.
3. Radioactive Contents - No more than 370.0 GBq (10.0 Ci) of Americium-241. The Am-241 is in the form of an oxide mixed with a beryllium powder that is pressed into a solid pellet.
4. Management System Activities - Records of Management System activities required by Paragraph 306 of the IAEA regulations shall be maintained and made available to the authorized officials for at least three years after the last shipment authorized by this certificate. Consignors in the United States exporting shipments under this certificate shall satisfy the requirements of Subpart H of 10 CFR 71.
5. Expiration Date - This certificate expires on December 31, 2027. Previous editions which have not reached their expiration date may continue to be used.

---

<sup>1</sup> "Regulations for the Safe Transport of Radioactive Material, 2012 Edition, No. SSR-6" published by the International Atomic Energy Agency (IAEA), Vienna, Austria.

<sup>2</sup> Title 49, Code of Federal Regulations, Parts 100-199, United States of America.

**CERTIFICATE USA/0758/S-96, REVISION 3**

This certificate is issued in accordance with paragraph(s) 804 of the IAEA Regulations and Section 173.476 of Title 49 of the Code of Federal Regulations, in response to the December 2, 2022 petition by QSA Global, Inc., Burlington, MA, and in consideration of other information on file in this Office.

Certified By:



December 12, 2022

(DATE)

 William Schoonover  
Associate Administrator for Hazardous  
Materials Safety

Revision 3 - Issued to extend the expiration date.

ITEM	DESCRIPTION	MATERIAL	No. OFF
1	INNER LID	MP35N	1
2	INNER BODY	MP35N	1
3	ACTIVE MATERIAL		

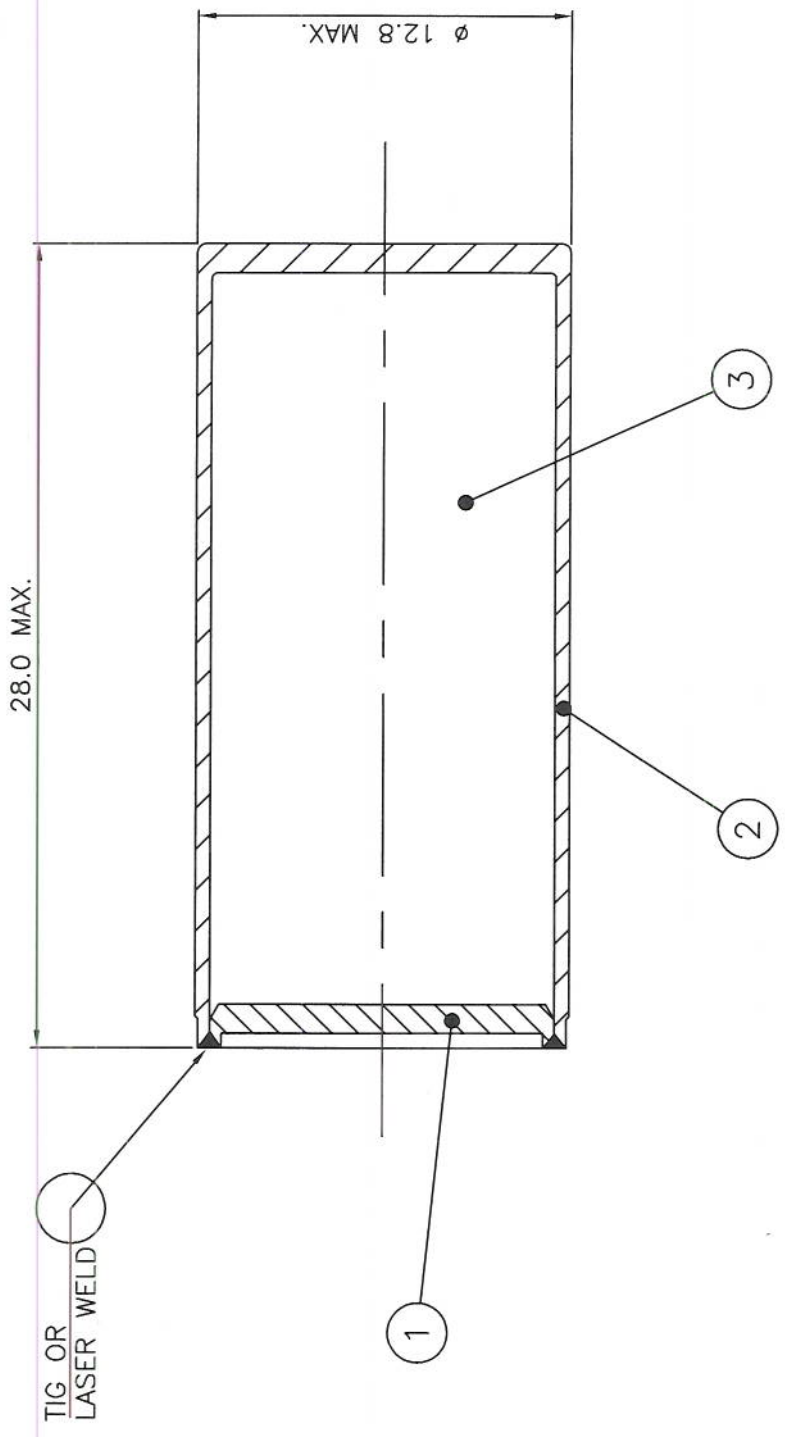

APPROVALS	DATE
<i>[Signature]</i>	3/20/08
<i>[Signature]</i>	3/10/08

UNLESS OTHERWISE SPECIFIED  
DIMENSIONS IN MILLIMETERS  
TOLERANCES:  
X ± 0.25  
XX ± 0.1  
XXX ± 0.01  
X.XXX ± 0.005



40 NORTH AVE, BURLINGTON, MA 01803

DESCRIPTIVE  
DRAWING

TITLE X9073 CAPSULE ASSEMBLY

SIZE	DWG. NO.	REV
A	RBA62948	
SCALE:	NTS	SHEET 1 OF 1

ERF # 1951



U.S. Department of  
Transportation

**Pipeline and  
Hazardous Materials  
Safety Administration**

East Building, PHH-23  
1200 New Jersey Ave, SE  
Washington, D.C. 20590

**CERTIFICATE NUMBER:** USA/0758/S-96

**ORIGINAL REGISTRANT(S) :**

QSA Global, Inc.  
40 North Avenue  
Burlington, MA, 01803  
USA