



STATE OFFICE FOR NUCLEAR SAFETY

Date: **04/04/2023**
Ref. no.: **SÚJB/ONRV/9588/2023**
File no.: **SÚJB/POD/5734/2023**
Section: **Radioactive Waste and Spent Fuel
Management Division
Senovážné náměstí 1585/9, 110 00 Prague**
Attended by: **Mgr. Martin Ansorge**
Phone: **+420 221 624 284**

DECISION

The State Office for Nuclear Safety (hereinafter referred to as the “SONS”), as the competent administrative body pursuant to Section 208(b) of Act No. 263/2016 Coll., the Atomic Energy Act (hereinafter referred to as the “Atomic Energy Act”), in the administrative proceedings for product type approval initiated pursuant to Section 44(1) of Act No. 500/2004 Coll, Rules of Administrative Procedure (hereinafter referred to as “RAP”), on the basis of an Application of 23 February 2023, ref. no. 34/EZC/2023, received by SONS on 23 February 2023, under ref. no. SÚJB/POD/5734/2023, submitted by the Participant in Proceedings

Person: **Eckert & Ziegler Cesio, s.r.o.**
Address: **Radiová 1, 102 27 Prague 10**
ID No.: **45274584**
SONS registration number: **108600,**

(hereinafter referred to as the “Participant in Proceedings”), within the meaning of Section 27(1)(a) of the Rules of Administrative Procedure, decided as follows:

In accordance with Section 67(1) of the Rules of Administrative Procedure and in accordance with Section 137(1)(b) of the Atomic Energy Act, SONS

approves the product type

construction type Am1.P08 and Am1.P081 special form radioactive material (hereinafter referred to as the “SFRM”), these SFRMs, manufactured in conformity with the documentation assessed, being assigned the identification designation

CZ/1010/S-96

and, for the purposes of international identification, this Am1.P08 and Am1.P081 SFRM type approval decision being assigned the code designation

CZ/1010/S-96 (Rev.3).

The SFRM under the identification designation CZ/1010/S-96 meets the requirements of the Atomic Energy Act and the relevant implementing regulations, the recommendations of the International Atomic Energy Agency (hereinafter referred to as "IAEA") "Regulations for the Safe Transport of Radioactive Material, 2018 Edition, Specific Safety Requirements No. SSR-6 (Rev. 1), IAEA, Vienna 2018" and the requirements of international transport regulations that refer to the cited IAEA rules.

Description of the SFRM

The SFRM under the identification designation CZ/1010/S-96 is a sealed radioactive source, which is produced in two construction types, which differ in the size of the outer capsule. Both types consist of a stainless steel capsule containing a ceramic carrier with homogeneously dispersed thermally fixed ^{241}Am radionuclide in the form of AmO_2 . The capsule is of cylindrical symmetry with a length of 10 mm and a diameter of 4.4 mm in the case of the Am1.P08 construction type or a diameter of 4.0 mm in the case of the Am1.P081 construction type. The capsule is sealed with a plug and sealed under a protective atmosphere (TIG weld) and bears a unique serial number.

The manufacturer of this SFRM is Eckert & Ziegler Cesio s.r.o., Radiová 1, 102 27 Prague 10.

SFRM Illustration

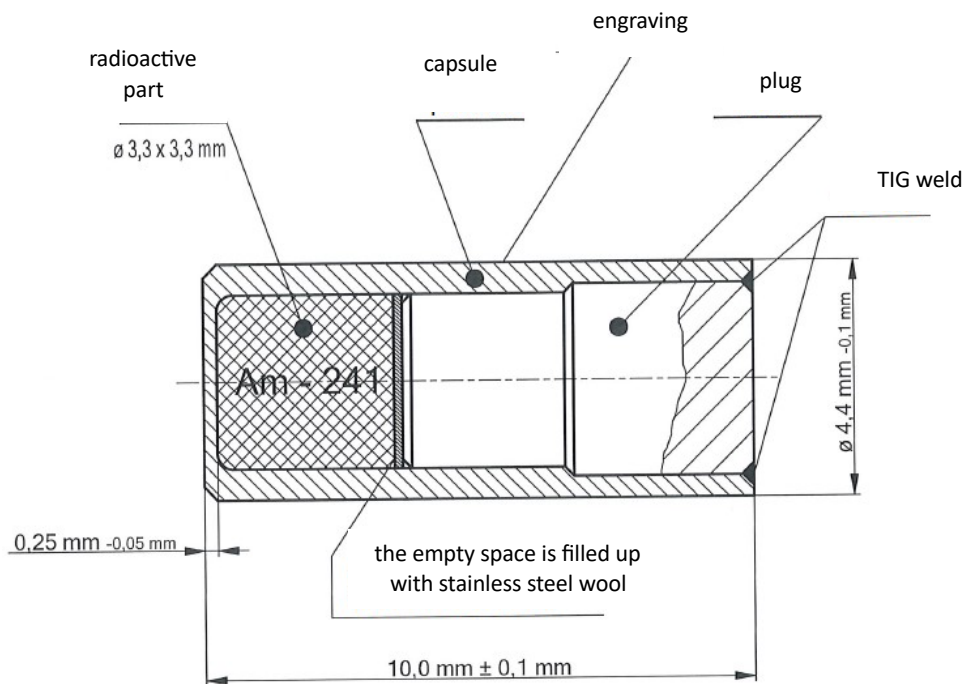

Note: after welding, the maximum length can be 10.3 mm

Figure 1: SFRM of the construction type Am1.P08. The illustration corresponds to the technical drawing "Am-241 source Am1.P08, 1.207.01.08-00:00(4), Eckert & Ziegler CESIO" of 25 August 2020.

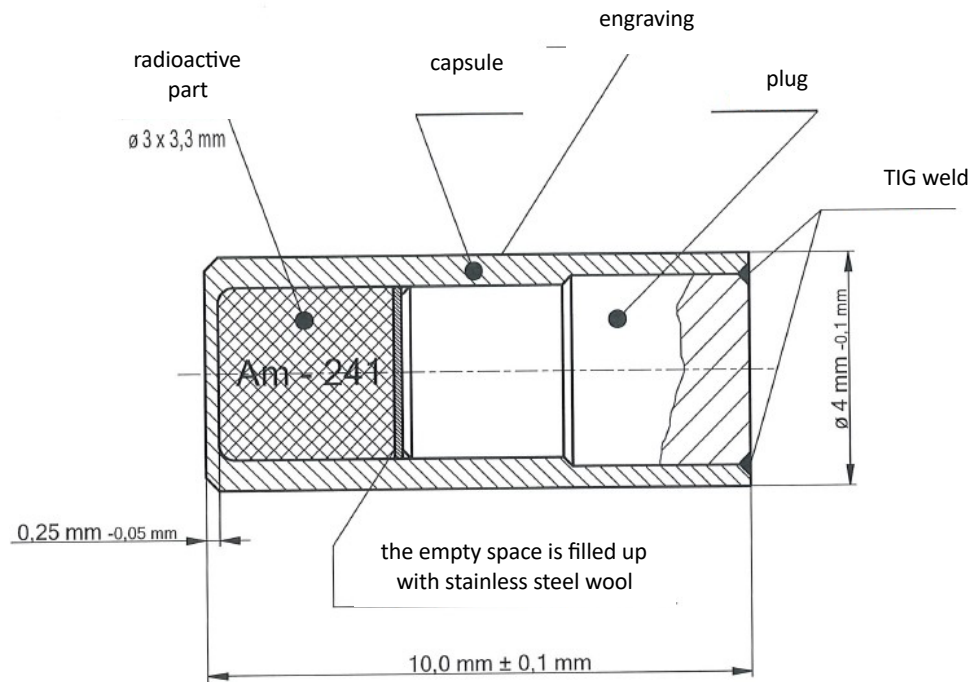

Note: after welding, the maximum length can be 10.3 mm

Figure 2: SFRM of the construction type Am1.P081. The illustration corresponds to the technical drawing "Am-241 source Am1.P081, 1.207.01.18-00:00(4), Eckert & Ziegler CESIO" of 25 August 2020.

SFRM Parameters

Construction type SFRM	Radionuclide	Maximum activity [GBq]	Length [mm]	Diameter [mm]	ISO Classification
Am1.P08	^{241}Am	11.1	10.0 + 0.3	4.4	C 64444
Am1.P081	^{241}Am	11.1	10.0 + 0.3	4.0	C 64444

Conditions of Use of the SFRM

The approved SFRM of the construction type Am1.P08 and Am1.P081 under the identification designation CZ/1010/S-96 may be used only if the following conditions are met:

1. Content of the SFRM

The SFRM of the construction type Am1.P08 and Am1.P081 under the identification designation CZ/1010/S-96 with a given serial number may contain only a radioactive source consisting of a solid ceramic carrier containing homogeneously dispersed and thermally fixed ^{241}Am radionuclide in the form of AmO_2 with a maximum activity of 11.1 GBq.

2. Handling, Maintenance and Inspections

Handling and maintenance of the SFRM of the construction type Am1.P08 or Am1.P081 under the identification designation CZ/1010/S-96 must be performed in compliance with the requirements given in the valid version of the document "Instructions for Safe Handling of Ionizing Radiation Sources (ZIZ), QM-RP-006, Eckert & Ziegler Cesio s.r.o."

The testing of the SFRM of the construction type Am1.P08 or Am1.P081, the acceptance test, the long-term stability test and the operating stability test must be carried out in accordance with

Section 68(1)(f), (2)(a) and Section 69(2)(c) of the Atomic Energy Act and subsequently according to Sections 26 to 31 of Decree

No. 422/2016 Coll. on Radiation Protection and Security of a Radioactive Source and according to ISO 9978:2020 "Radiation Protection – Sealed Sources – Leakage Test Methods, ISO, Geneva 2020" and must be documented and archived for the entire lifetime of the SFRM.

3. Quality Assurance

The SFRM of the construction type Am1.P08 under the identification designation CZ/1010/S-96 with the given serial number shall be manufactured in accordance with the technical drawing "Am-241 source Am1.P08, 1.207.01.08-00:00(4), Eckert & Ziegler CESIO," 20 August 2020.

The SFRM of the construction type Am1.P081 under the identification designation CZ/1013/S-96 with the given serial number shall be manufactured in accordance with the technical drawing "Am-241 source Am1.P081, 1.207.01.18-00:00(4), Eckert & Ziegler CESIO," 20 August 2020.

Manufacture must be carried out in accordance with the approved procedures, the document "Management System, QM-RP-001, Eckert & Ziegler Cesio s.r.o." as amended, and the requirements of Decree No. 408/2016 Coll., on Requirements for the Management System.

The conformity of the SFRM of the construction type Am1.P08 and Am1.P081 with the approved type must be documented by the manufacturer by means of a written declaration of conformity prepared in accordance with the requirements of Section 140 of the Atomic Energy Act.

4. Reporting of Accidents

If any defect or accident occurs during the handling and manipulation of the SFRM under the identification designation CZ/1010/S-96 of the construction type Am1.P08 or Am1.P081, in particular if it falls or is damaged, the SFRM of the construction type Am1.P08 or Am1.P081 must be temporarily put out of operation without unnecessary delay, in compliance with all radiation protection requirements. Such a SFRM can only be put back into service after an inspection or repair. At the same time, a report of the event will be prepared and sent to SONS by the licence holder pursuant to Section 9(2)(f) of the Atomic Energy Act as amended within 14 days of the occurrence of the event.

5. Validity of the Decision

This Decision shall be enforceable from 1 December 2023.

This Decision expires on 30 November 2033.

Justification

Pursuant to Section 44(1) of the Rules of Administrative Procedure, SONS initiated administrative proceedings with the participant in the matter of product type approval of a special form radioactive material on the basis of an Application submitted by the Participant in Proceedings on 23 February 2023, ref. no. 34/EZC/2023, which was received on 23 February 2023 and assigned ref. no. SÚJB/POD/5734/2023. SONS appointed Mgr. Martin Ansorge as the authorised official for the management of the proceedings.

The decision is issued after the assessment of the submitted documentation, which has been submitted to SONS in connection with the provisions of Section 138 of the Atomic Energy Act and subsequently with the provisions of Section 12(1) and (2)(b) of Decree No. 379/2016 Coll., on the type approval of some products in the field of peaceful uses of nuclear energy and ionising radiation and the carriage of radioactive or fissile material and the relevant items of Annex 4 to this Decree.

In accordance with the above-mentioned legal provisions, the applicant's application was supported by the information, documents and documentation listed below:

1. Identification of the applicant (Section 138(1) of the Atomic Energy Act)
Eckert & Ziegler Cesio s.r.o., Radiová 1, 102 27 Prague 10, ID No. 45274584, registration No. 108600
Statutory body, Ing. Ivan Šimmer (hereinafter referred to as the "Executive"), Za Strouhami 1041, 250 52 Karlík, Birth No. 620729/0826
 - Extract from the Register of Companies kept by the Municipal Court in Prague, Section C, Insert 9375 of Eckert & Ziegler Cesio s.r.o. dated 25 January 2023, verified by Vyskočilová Jana
 - Affirmation of the Executive on the professional competence, ref. no. 34/EZC/2023 of 23 February 2023
 - Proof of professional competence of the Executive, copy of the diploma of the University of Chemical Technology in Prague No. 4756 dated 9 June 1984
 - Affirmation of the Executive on the criminal integrity of 1 February 2023
 2. Identification of the manufacturer (Section 138(2)(a) of the Atomic Energy Act) The applicant is the manufacturer.
 3. Product identification (Section 138(2)(b) of the Atomic Energy Act)
Specified in the Application, part (b) and described in more detail in Annex 1 of the document "Type Description of the SFRM type Am1.P08, Am1.P081": The SFRM of the construction type Am1.P08 and Am1.P081 is a sealed radioactive source containing the ²⁴¹Am radionuclide in the form of AmO₂ thermally fixed in a ceramic carrier. The only difference between the two construction types is the diameter of the capsule.
 4. Description of use (Section 138(2)(c) of the Atomic Energy Act)
Indicated in the application, part (c): The SFRM of the construction type Am1.P08 and Am1.P081 is used as a part of measuring and control equipment in industry and oil exploration where the use of other methods is impossible or uneconomical. The recommended period of use is 15 years.
 5. A list of legislation and technical standards in accordance with which the product was designed and manufactured (Section 138(2)(d) of the Atomic Energy Act) Listed in the Application, part (d), namely:
 - Act No. 263/2016 Coll., the Atomic Energy Act
 - Decree No. 422/2016 Coll.
 - Decree No. 408/2016 Coll.
 - Decree No. 379/2016 Coll.
 - ISO 9978:2020 Radiation protection – Sealed radioactive sources – Leakage test methods
 - ISO 2919:2012 Radiological protection – Sealed radioactive sources – General requirements and classification
 - ISO 9001:2015 – Quality Managements Systems – Requirements
 - ČSN EN 10204 Metal Products – Types of Control Documents
-

-
6. Proposal for the scope and method of carrying out operating inspections (Section 138(2)(e) of the Atomic Energy Act) Set out in the application, part (e), specifically Tables 1 to 3. Operating inspections are carried out by means of an acceptance test, a long-term stability test and an operating stability test. A report shall be drawn up on the result of each test.
 7. Passport Sheet in Czech, comprising rules for the safe handling and maintenance of the product (Section 138(2)(f) of the Atomic Energy Act)
The application in part f) refers to Annex 3 of the document "Instructions for the Safe Handling of Ionizing Radiation Sources, QM-RP-006, Eckert & Ziegler Cesio s.r.o.", version 4 of 11 February 2021.
 8. Required period of validity of the product type approval decision (Section 138(2)(g) of the Atomic Energy Act)
Specified in the application, section (g): The required period of validity of the product type approval decision is 10 years.
 9. Material specifications of the radioactive or fissile material contents, including a description of their physical and chemical states (Annex 2(d)(1) of the Atomic Energy Act)
Specified in the application in part (d)(1): The active part of the SFRM of the construction type Am1.P08 and Am1.P081 consists of the ²⁴¹Am radionuclide in the form of AmO₂, which is homogeneously dispersed and thermally fixed in the ceramic material.
 10. Description of the product construction type and the manufacturing and technological documentation with a description of the material and technological methods used in the manufacture (Annex 2(d)(2) of the Atomic Energy Act) The Application in part (d)(2) refers to Annex 1 of the document "Type Description of the Am1.P08, Am1.P081, Am1.P08 and Am1.P081 Sealed Radioactive Source, Eckert & Ziegler Cesio s.r.o.", version no. 2 of 23 February 2023.
 11. Documentation of tests or calculations and analyses with their independent verification by an authorised person (Annex 2(d)(3) of the Atomic Energy Act and Section 12(1) and (2)(b) of Decree No. 379/2016 Coll.)
The Application in part (d)(3) refers to Annex 4 of the document "Zertifikat der ISO-Klasifikation, ZI2096, BEBIG Isotopentechnik und Umweltdiagnostik GmbH Berlin" of 25 August 1996 for the construction type Am1.P08 and "Zertifikat der ISO-Klasifikation, ZI2196, BEBIG Isotopentechnik und Umweltdiagnostik GmbH Berlin" of 28 October 1996 for the construction type Am1.P081. An analysis of the test results is further provided in Annex 5 in the document "Evaluation of the SFRM Tests."
 12. Manufacturer's management system programme (Annex 2(d)(4) of the Atomic Energy Act)
The application in part d) 4 refers to Annex 6 of the document "Management System, QM-RP-001, Eckert & Ziegler Cesio s.r.o.", version 1 of 3 June 2019 and its annexes:
 - Specification of radionuclides and maximum activity for each disposal route of 3 June 2019
 - Controlled & monitored area plans of 3 June 2019
 - Radiation Protection – List of Documents, QM-RP-000, Version 4 of 3 June 2019
 - Index to Manufacturing Process Documentation, QM-P-000, Version 3 of 25 August 2016
 - Inspection and Testing – Documentation Index, QM-T-000, Version 6 of 29 June 2022
 - Monitoring Programme, QM-RP-005, Version 7 of 15 December 2017
 - Security of Radioactive Sources, QM-RP-007, Version 1 of 20 March 2018
 - Internal Directive on Records and Inspection of Nuclear Material, QM-RP-008, Version 4 of 15 November 2017
 - Internal Control Program, QM-Q-971-1, Version 2 of 3 April 2018
 13. Description of the measures proposed for the handling of the product necessary for transport (Annex 2(d)(5) of the Atomic Energy Act and relevant requirements of Annex 4 of Decree No 379/2016 Coll.) Listed in the application, part d) 5: The products will be transported in type A packages (UN 3332, maximum activity value corresponding to A₁ and at the same time radiation dose rate on the surface of the consignment maximum 2 mSv/h and at a distance of 1 m maximum 100 µSv/h, consignment marking according to Decree No. 379/2016 Coll.), B(U) (UN 2916, conditions of transport according to the decision on approval of the respective construction types of packages) and, if applicable, in the package for the excepted quantity (UN 2910, activity value
-

corresponding to 0.001A₁ at most and at the same time a radiation dose rate on the surface of the consignment of less than 5 µSv/h, consignment designation according to Decree No. 379/2016 Coll.).

The transport will be carried out by a vehicle equipped according to ADR, the driver of the vehicle will have a valid licence for the transport of dangerous goods according to the ADR.

Instructions for the safe handling of SFRM are also provided in Annex 3 of the document "Instructions for Safe Handling of Ionizing Radiation Sources (ZIZ), QM-RP-006, Eckert & Ziegler Cesio s.r.o.", version 4, dated 11 February 2021.

14. Reproducible illustration of the appearance of the product with maximum dimensions of 21 cm × 29.7 cm (Annex 2(d)(6) of the Atomic Energy Act)

The Application in part (d)(6) refers to Annex 2 of the document "SFRM drawing of the Am1.P08, Am1.P081 construction type", technical drawing "Am-241 source Am1.P08, 1.207.01.08-00:00(4), Eckert & Ziegler CESIO" of 25 August 2020 and "Am-241 source Am1.P081, 1.207.01.18-00:00(4), Eckert & Ziegler CESIO" of 25 August 2020.

SONS examined the application in terms of the requirements under the cited provisions of the Atomic Energy Act and found it sufficient. SONS therefore concludes that the assessed safety documentation complies with the relevant provisions of the Atomic Energy Act and the relevant provisions of Decree No. 379/2016 Coll. and demonstrates the suitability of the SFRM of the construction type Am1.P08 and Am1.P081 as described in Condition 1 for its use in accordance with the other conditions of this Decision.

In the conclusion of the Application ref. no. 34/EZC/2023 of 23 February 2023, the applicant waived the right to participate in the evidence in the proceedings initiated on the basis of the Application within the meaning of Section 51(2) of the Rules of Administrative Procedure and the right to comment on the grounds for the decision in the proceedings initiated on the basis of the above-mentioned Application within the meaning of Section 36(3) of the Rules of Administrative Procedure.

A record of the out-of-court evidence was prepared on 31 March 2023 under ref. no. SÚJB/ONRV/9256/2023.

The administrative fee within the meaning of Act No. 634/2004 Coll., on Administrative Fees in the amount of CZK 1,000 was paid in accordance with Item no. 107(3)(b) of administrative fee tariff.

Advice

Remonstrance against this Decision can be lodged to SONS's Chairperson through SONS, Nuclear Safety Section, Senovážné náměstí 9, 110 00 Prague 1, within 15 days after the service hereof.

On behalf of the State Office for Nuclear Safety

RNDr. Peter Lietava
Head of the Radioactive Waste and Spent Fuel

Management Division

Distribution list:

- SONS, Department of RaO and VJP Management
- Eckert & Ziegler Cesio s.r.o., Radiová 1, 102 27 Prague 10

RNDr. Peter Lietava
04/04/2023 02:34:42 pm

Translator's Affidavit

I swear that I am a court translator of the English language appointed by the Regional Court in Ostrava, the Czech Republic, on 19 July 2019, adjudication file number Spr 2390/2018, and I hereby confirm that the attached English text is a true and complete translation of the Czech original herewith. The serial number of this certified translation in the Translator's Register is 051169/2023.

Ing. Mgr. Pavel Brunda, Ph.D.
Dated 12 May 2023