



U.S. Department
of Transportation

Pipeline and
Hazardous Materials
Safety Administration

East Building, PHH-23
1200 New Jersey Ave, SE
Washington, D.C. 20590

IAEA CERTIFICATE OF COMPETENT AUTHORITY
SPECIAL FORM RADIOACTIVE MATERIALS

CERTIFICATE USA/0292/S-96, REVISION 10

This certifies that the sources described have been demonstrated to meet the regulatory requirements for special form radioactive material as prescribed in the regulations of the International Atomic Energy Agency¹ and the United States of America² for the transport of radioactive material.

1. Source Identification - Neutron Products, Inc. Model Nos. NPI-XX-XXXX, NPI-XX-XXXXW, NPI-XX-XXXXR, NPI-XX-XXXXCR, and NPI-XX-XXXXRC; where XX represents the nominal diameter in mm, XXXX represents the nominal source intensity in roentgens per hour at one meter, and W, R, CR, and RC represent the form of the radioactive contents.
2. Source Description - Cylindrical double encapsulations made of Type 304L or Type 316L stainless steel. Approximate outer dimensions are between 23.6 mm (0.93 in.) and 38.0 mm (1.50 in.) in diameter and between 33.0 mm (1.30 in.) and 42.0 mm (1.65 in.) in length. An internal tungsten shield may be used on the Model NPI-XX-XXXXW and a stainless steel inner shield may be used on the Model NPI-XX-XXXX. Construction shall be in accordance with attached Neutron Products Inc. Drawing No. 200383.
3. Radioactive Contents - No more than 444.0 TBq (12,000.0 Ci) of Cobalt-60 for the Model Nos. NPI-XX-XXXX and NPI-XX-XXXXW. The Co-60 is in the form of metal wafers or a solid slug. No more than 555.0 TBq (15,000.0 Ci) of Cobalt-60 for the Model Nos. NPI-XX-XXXXR, NPI-XX-XXXXCR, and NPI-XX-XXXXRC. The Co-60 is in the form of metal wafers, metal casting, or metal rods.

¹ "Regulations for the Safe Transport of Radioactive Material, 2012 Edition, No. SSR-6" published by the International Atomic Energy Agency (IAEA), Vienna, Austria.

² Title 49, Code of Federal Regulations, Parts 100-199, United States of America.

CERTIFICATE USA/0292/S-96, REVISION 10

4. Management System Activities - Records of Management System activities required by Paragraph 306 of the IAEA regulations shall be maintained and made available to the authorized officials for at least three years after the last shipment authorized by this certificate. Consignors in the United States exporting shipments under this certificate shall satisfy the requirements of Subpart H of 10 CFR 71.

5. Expiration Date - This certificate expires on September 30, 2026. Previous editions which have not reached their expiration date may continue to be used.

This certificate is issued in accordance with paragraph(s) 804 of the IAEA Regulations and Section 173.476 of Title 49 of the Code of Federal Regulations, in response to the September 15, 2021 petition by Neutron Products, Inc., Dickerson, MD, and in consideration of other information on file in this Office.

Certified By:



September 24,
2021

 _____
William Schoonover
Associate Administrator for Hazardous
Materials Safety

(DATE)

Revision 10 - Issued to extend the expiration date.

CATALOG No NPI XX-XXXX
 AND NPI XX-XXXXW
 WHERE: FIRST TWO DIGITS ARE
 ACTIVE DIAMETER(D) IN MM
 LAST DIGITS EQUAL THE
 DOSE RATE IN RHM
 D=05, 10, 15, 20 OR 25MM

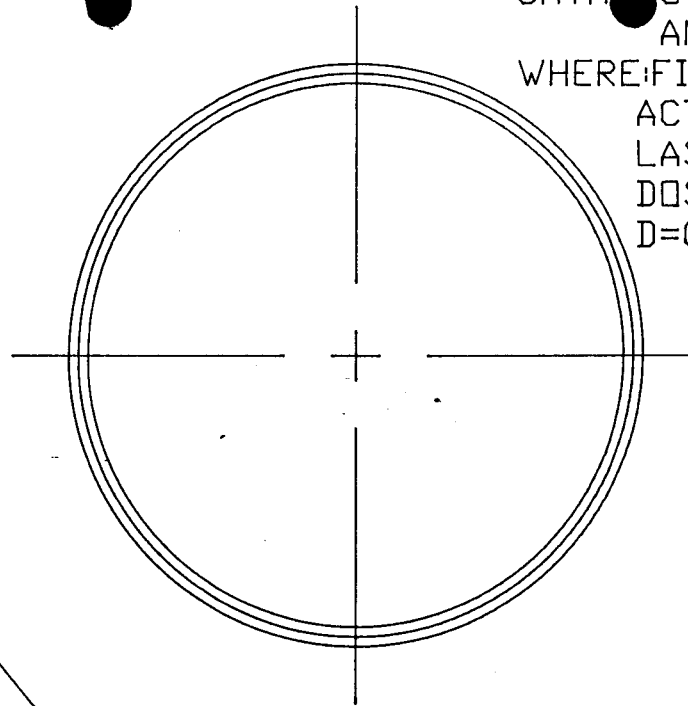

WELD PER NPI
 SPEC P-4
 (JAN 11-1971)

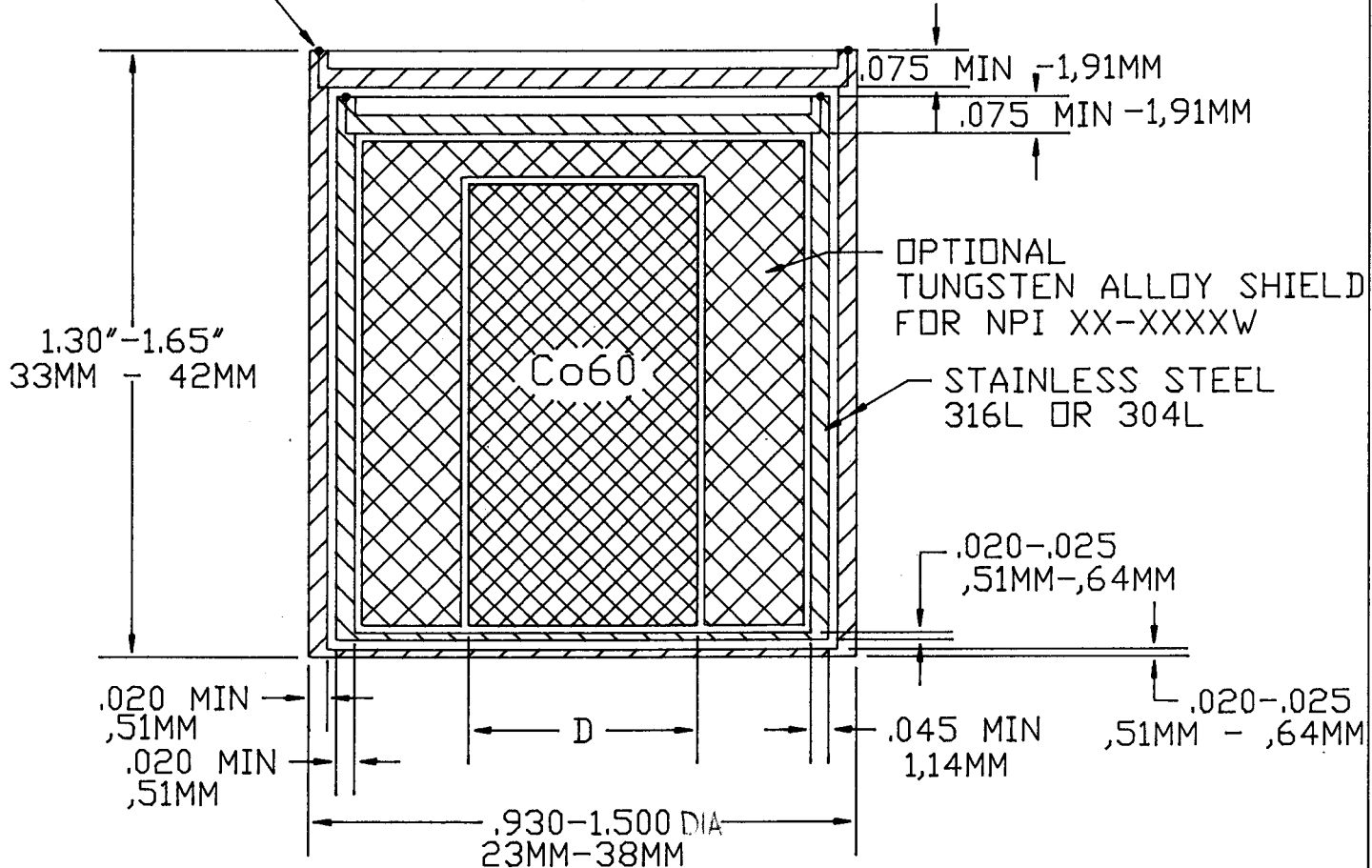

UNLESS OTHERWISE SPECIFIED DIMENSIONS ARE IN INCHES		NEUTRON PRODUCTS INC		
TOLERANCES ANGULAR DECIMAL FRACTIONAL		TITLE		APPROVED
		<u>TELETHERAPY</u> <u>SOURCE</u>		ISSUED DATE
DRAWN JG 1-31-97		SIZE A	DVG. NO. 200383	REV
DESIGN MT 1-31-97		SCALE 2/1		SHEET 1 OF 1
CHECKED <i>[Signature]</i> 1/31/97				



U.S. Department of
Transportation

**Pipeline and
Hazardous Materials
Safety Administration**

East Building, PHH-23
1200 New Jersey Ave, SE
Washington, D.C. 20590

CERTIFICATE NUMBER: USA/0292/S-96

ORIGINAL REGISTRANT(S) :

Neutron Products, Inc.
22301 Mt. Ephraim Road
P.O. Box 68
Dickerson, MD, 20842
USA