



U.S. Department  
of Transportation

Pipeline and  
Hazardous Materials  
Safety Administration

East Building, PHH-23  
1200 New Jersey Ave, SE  
Washington, D.C. 20590

IAEA CERTIFICATE OF COMPETENT AUTHORITY  
SPECIAL FORM RADIOACTIVE MATERIALS

CERTIFICATE USA/0462/S-96, REVISION 9

This certifies that the sources described have been demonstrated to meet the regulatory requirements for special form radioactive material as prescribed in the regulations of the International Atomic Energy Agency<sup>1</sup> and the United States of America<sup>2</sup> for the transport of radioactive material.

1. Source Identification - Eckert & Ziegler Isotope Products Models 3021-1 (formerly 3021), 3021-2 and 3027.
2. Source Description - Cylindrical double (Model 3021-2) or triple (Models 3021-1 and 3027) encapsulations made of either Type 304 (Models 3021-1 and 3021-2) or Type 316 (Model 3027) stainless steel and fusion seal welded. Approximate outer dimensions are 12.7 mm (0.5 in.) in diameter and either 12.7 mm (0.5 in.) (Models 3021-1 and 3021-2) or 19.1 mm (0.75 in.) (Model 3027) in length. The inner encapsulation of the Models 3021-1 and 3027 is a QSA Global, Inc. (formerly AEA Technology QSA, Inc. and Amersham) Model X.1. Construction shall be in accordance with attached Eckert & Ziegler Isotope Products Drawing No. 3021-REG, Rev. B, Sheet 1 of 2 (Model 3021-1) or Sheet 2 of 2 (Model 3021-2) or Isotope Products Laboratories Drawing No. 3027, Rev. C, Sheet 3 of 7 (Model 3027).
3. Radioactive Contents - No more than 1.48 GBq (40.0 mCi) of Americium-241 for the Models 3021-1 and 3027. No more than 3.7 GBq (100.0 mCi) of Americium-241 for the Model 3021-2. The Am-241 is in the form of an oxide mixed with beryllium powder (Models 3021-1 and 3027) or in the form of an oxide mixed with beryllium powder as a compressed powder pellet (Model 3021-2).

---

<sup>1</sup> "Regulations for the Safe Transport of Radioactive Material, 2012 Edition, No. SSR-6" published by the International Atomic Energy Agency (IAEA), Vienna, Austria.

<sup>2</sup> Title 49, Code of Federal Regulations, Parts 100-199, United States of America.

**CERTIFICATE USA/0462/S-96, REVISION 9**

4. Management System Activities - Records of Management System activities required by Paragraph 306 of the IAEA regulations shall be maintained and made available to the authorized officials for at least three years after the last shipment authorized by this certificate. Consignors in the United States exporting shipments under this certificate shall satisfy the requirements of Subpart H of 10 CFR 71.
  
5. Expiration Date - This certificate expires on August 31, 2026. Previous editions which have not reached their expiration date may continue to be used.

This certificate is issued in accordance with paragraph(s) 804 of the IAEA Regulations and Section 173.476 of Title 49 of the Code of Federal Regulations, in response to the August 16, 2021 petition by Eckert & Ziegler Isotope Products, Valencia, CA, and in consideration of other information on file in this Office.

Certified By:



William Schoonover  
Associate Administrator for Hazardous  
Materials Safety

August 31, 2021  
(DATE)

Revision 9 - Issued to extend the expiration date.

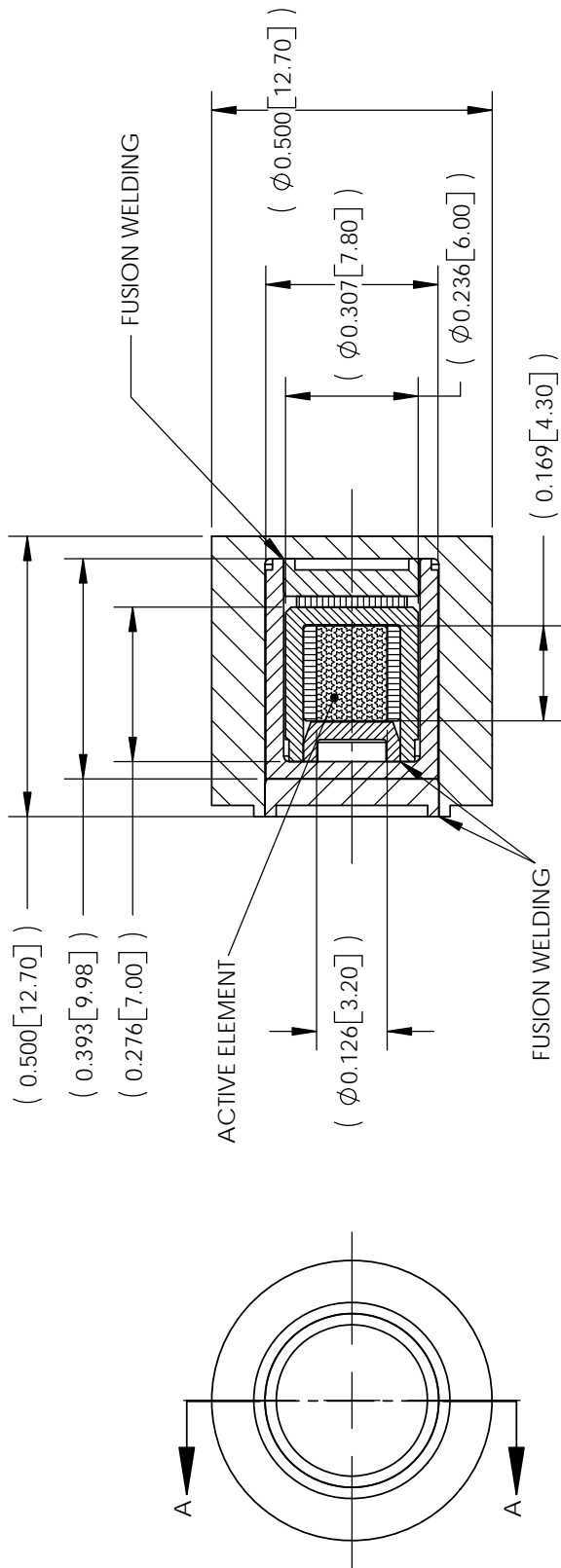

SECTION A-A

ENGRAVING LETTERS-1/16" HIGH  
 RADIATION SYMBOL OR THE WORD "Radioactive",  
 Nuclide,  
 Activity,  
 Serial Number

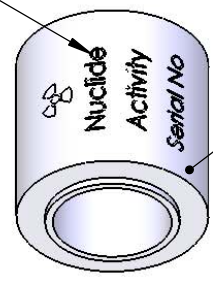

3. AEA X.1 INNER CAPSULE  
 2. ENGRAVED INFORMATION MAY BE ON THE SIDE OF THE CAPSULE OR ON THE WINDOW.  
 1. P/N A3021-1 WAS FORMERLY A3021.  
 NOTES: UNLESS OTHERWISE SPECIFIED

<p>UNLESS OTHERWISE SPECIFIED DIMENSIONS ARE IN INCH-SIZES. METRIC UNITS [mm] ARE IN MILLIMETERS.</p>		<p>TITLE</p> <p>MODEL 3021 SERIES</p> <p>SERIES TITLE</p> <p>HIGH INTENSITY GAMMA AND NEUTRON SOURCES</p>	<p>REV</p> <p>B</p>	<p>SHEET</p> <p>1 OF 2</p>
<p>DRAWN</p> <p>KP</p>	<p>ME/CHECKER</p> <p>EZ</p>	<p>CAGE CODE</p> <p>32993</p>	<p>DRAWING NO.</p> <p>3021-REG</p>	
<p>ENGINEER</p> <p>EZ</p>	<p>SCALE</p> <p>NONE</p>	<p>SIZE</p> <p>A</p>		
<p>THIRD ANGLE PROJECTION</p>				
<p><b>Eckert &amp; Ziegler</b></p> <p>Isotope Products</p> <p>VALENCIA, CALIFORNIA 91355</p>		<p>THIS DRAWING IS THE PROPERTY OF ECKERT &amp; ZIEGLER ISOTOPE PRODUCTS AND MAY NOT BE USED, REPRODUCED, PUBLISHED OR DISCLOSED TO OTHERS WITHOUT EXPRESS AUTHORIZATION BY ECKERT &amp; ZIEGLER ISOTOPE PRODUCTS.</p>		

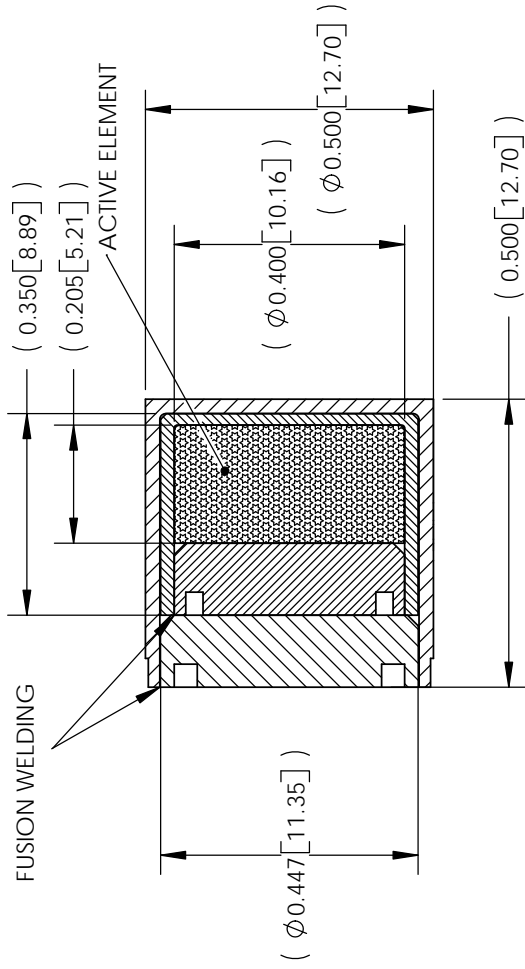
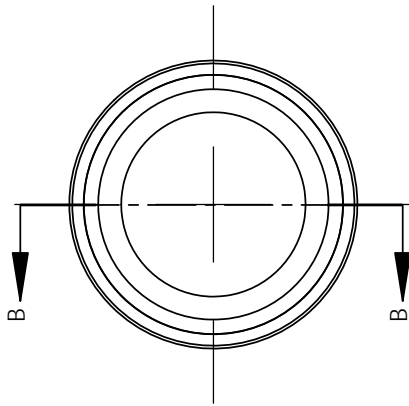

SECTION B-B

ENGRAVING LETTERS-1/16" HIGH  
RADIATION SYMBOL OR THE WORD "Radioactive",  
Nuclide,  
Activity,  
Serial Number

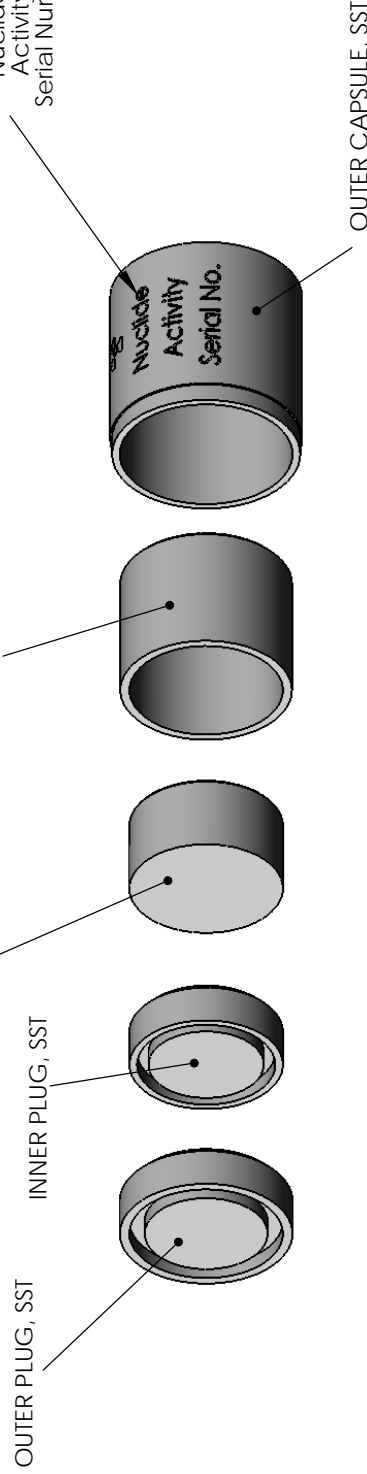

MODEL VIEW (NOT TO SCALE)

△ ENGRAVED INFORMATION MAY BE ON THE SIDE OF THE CAPSULE OR ON THE WINDOW.  
1. P/N A3021-2 WAS FORMERLY RFO885.  
NOTES: UNLESS OTHERWISE SPECIFIED

P/N A3021-2 AmBe SEALED SOURCE ASSEMBLY II

 VALENCIA, CALIFORNIA 91355	UNLESS OTHERWISE SPECIFIED DIMENSIONS ARE IN INCH-SIZES. METRIC UNITS [mm] ARE IN MILLIMETERS.		DRAWN KP	TITLE MODEL 3021 SERIES	
			ME/CHECKER EZ	SERIES TITLE HIGH INTENSITY GAMMA AND NEUTRON SOURCES	
		ENGINEER EZ	SCALE NONE	CAGE CODE 32993	DRAWING NO. 3021-REG
		THIRD ANGLE PROJECTION 	SIZE A	REV B	SHEET 2 OF 2

THIS DRAWING IS THE PROPERTY OF ECKERT & ZIEGLER ISOTOPE PRODUCTS AND MAY NOT BE USED, REPRODUCED, PUBLISHED OR DISCLOSED TO OTHERS WITHOUT EXPRESS AUTHORIZATION BY ECKERT & ZIEGLER ISOTOPE PRODUCTS.

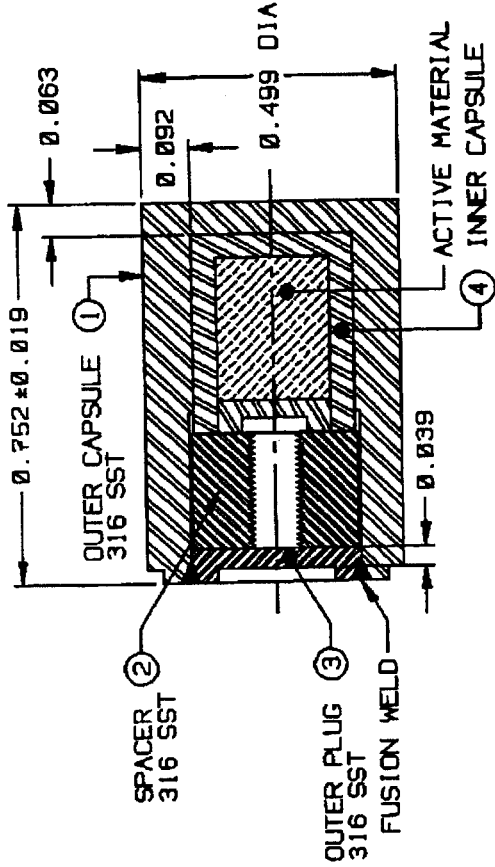
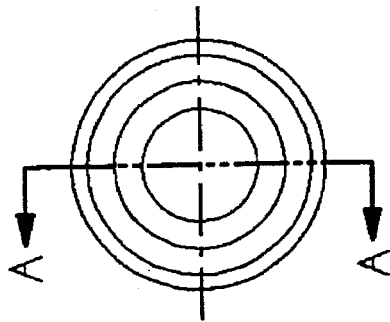

SECTION A-A

P/N: A3027 ASSEMBLY

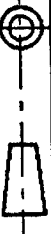
 <b>ISOTOPE PRODUCTS LABORATORIES</b> BURBANK, CALIFORNIA 91504	UNLESS OTHERWISE SPECIFIED DIMENSIONS ARE IN INCHES		DESIGN JMD/RLT	DRAWING TITLE AmBe NEUTRON SOURCE
	FRAC- TION ±1/64	DECIMAL X .01	TOLERANCES ON XXX XX XXX .002	SCALE NONE
THIRD ANGLE PROJECTION 			SIZE A	CAGE CODE 32983
THIS DRAWING IS THE PROPERTY OF ISOTOPE PRODUCTS LABORATORIES AND MAY NOT BE USED, REPRODUCED, PUBLISHED OR DISCLOSED TO OTHERS WITHOUT EXPRESS AUTHORIZATION BY ISOTOPE PRODUCTS LABORATORIES.			REVISION C	DRAWING NUMBER 3027
			SHEET 3 OF 7	



U.S. Department of  
Transportation

**Pipeline and  
Hazardous Materials  
Safety Administration**

East Building, PHH-23  
1200 New Jersey Ave, SE  
Washington, D.C. 20590

**CERTIFICATE NUMBER:** USA/0462/S-96

**ORIGINAL REGISTRANT(S) :**

Eckert & Ziegler Isotope Products  
24937 Avenue Tibbitts  
Valencia, CA, 91355  
USA