



U.S. Department
of Transportation

Pipeline and
Hazardous Materials
Safety Administration

East Building, PHH-23
1200 New Jersey Ave, SE
Washington, D.C. 20590

IAEA CERTIFICATE OF COMPETENT AUTHORITY
SPECIAL FORM RADIOACTIVE MATERIALS

CERTIFICATE USA/0516/S-96, REVISION 5

This certifies that the sources described have been demonstrated to meet the regulatory requirements for special form radioactive material as prescribed in the regulations of the International Atomic Energy Agency¹ and the United States of America² for the transport of radioactive material.

1. Source Identification - Eckert & Ziegler Isotope Products (EZIP) source capsule Models 3224-01, 3224-02, 3224-03, 3224-05, 3224-11, 3224-12, 3224-13, 3224-15, and 3807.
2. Source Description - Cylindrical single encapsulations made of Type 304 or 304L stainless steel or titanium, with a 0.25 mm (0.010 in.) thick integral window at one end, and fusion seal welded. Approximate outer dimensions of the 3224 models are either 2.0 mm (0.08 in.), 3.0 mm (0.12 in.), 4.0 mm (0.16 in.), or 7.0 mm (0.28 in.) in diameter and 10.0 mm (0.39 in.) in length. Approximate outer dimensions of the 3807 model are 3.0 mm (0.12 in.) in diameter and 10.2 mm (0.4 in.) in length. Construction of capsule 3224 models shall be in accordance with Eckert & Ziegler Isotope Products Drawing No. 3224, Rev. S, sheet 3 of 5. Construction of the 3807 model shall be in accordance with attached Isotope Products Laboratories Drawing No. 3807, Rev. B, Sheet 3 of 6.
3. Radioactive Contents - The sources described by this certificate are authorized to contain any one of the following radionuclides limited to the activity shown. The radionuclides are in the form of chlorides, nitrates, or oxides in ceramic or resin bead; oxides in gold or aluminum; or metal plated onto substrate.

¹ "Regulations for the Safe Transport of Radioactive Material, 2012 Edition, No. SSR-6" published by the International Atomic Energy Agency (IAEA), Vienna, Austria.

² Title 49, Code of Federal Regulations, Parts 100-199, United States of America.

CERTIFICATE USA/0516/S-96, REVISION 5

The Na-22 may also be in the form of NaCl in gold. The Ge-68 may also be in the form of GeO₂ in silver. The Sr-90 may also be in the form of SrTiO₄ in silver. The Ba-133 may also be in the form of BaSO₄ in ceramic.

Radionuclide Activity MBq (mCi)

Na-22	185	(5)
Co-57	11,100	(300)
Co-58	11,100	(300)
Co-60	370	(10)
Ge-68	1,850	(50)
Sr-90	4,625	(125)
Ru-106	1,850	(50)
Ba-133	3,700	(100)
Cs-137	11,100	(300)
Ra-226	1,850	(50)
Lanthanides*	11,100	(300)
Actinides**	11,100	(300)

* (Isotopes of Ce, Pr, Sm, Eu, Gd, Tm, and Yb only)

** (Isotopes of Ac, Th, Pa, U, Pu, Am, and Cm only)

4. Management System Activities - Records of Management System activities required by Paragraph 306 of the IAEA regulations shall be maintained and made available to the authorized officials for at least three years after the last shipment authorized by this certificate. Consignors in the United States exporting shipments under this certificate shall satisfy the requirements of Subpart H of 10 CFR 71.
5. Expiration Date - This certificate expires on February 28, 2024. Previous editions which have not reached their expiration date may continue to be used.

CERTIFICATE USA/0516/S-96, REVISION 5

This certificate is issued in accordance with paragraph(s) 804 of the IAEA Regulations and Section 173.476 of Title 49 of the Code of Federal Regulations, in response to the December 19, 2018 petition by Eckert & Ziegler Isotope Products, Valencia, CA, and in consideration of other information on file in this Office.

Certified By:



February 21, 2019

(DATE)

 William Schoonover
Associate Administrator for Hazardous
Materials Safety

Revision 5 - Issued to extend the expiration date and to add Models 3224-05 and 3224-15.

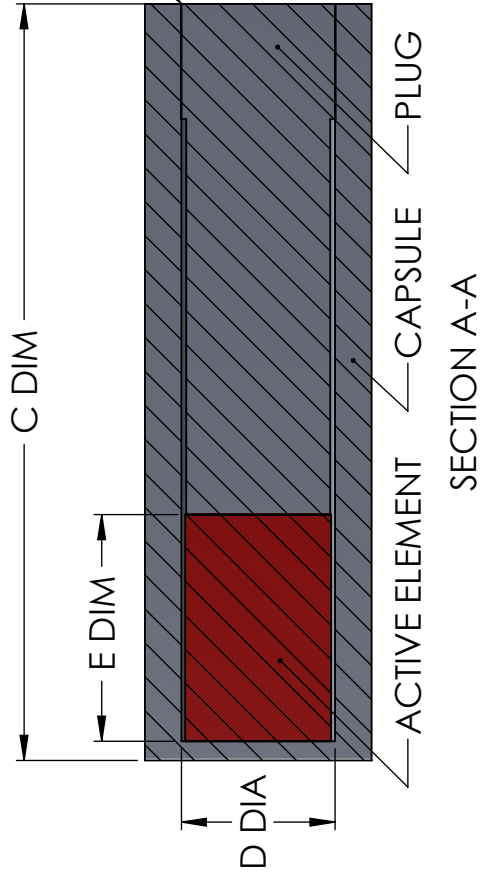

TABLE 1

X	MATERIAL
0	304 OR 304L SST
1	TITANIUM

TABLE 2

Y	A DIA	B DIA	C DIM	D DIA	E DIM
1	0.118	0.0800	0.394	0.076	0.118
2	0.157	0.1200	0.394	0.116	0.115
3	0.275	0.1870	0.394	0.182	0.160
4	0.118	0.0980	0.197	0.093	0.030
5	0.079	0.0460	0.394	0.039	0.079
6	0.079	0.0460	0.197	0.039	0.039

TABLE 3

Z	ENGRAVED CAPSULE
0	EZIP, NUCLIDE, ACTIVITY, S/N
1	EZIP, Co-57 50 μ Ci S/N
2	EZIP, Co-57 1 mCi S/N
3	EZIP, Co-57 10 mCi S/N
4	EZIP, Co-57 15 mCi S/N
5	EZIP, Co-57 20 mCi S/N
6	EZIP, Co-57 5 mCi S/N

3. PACKAGE AND IDENTIFY PART NUMBER THEREON
 2. ASSEMBLE COMPLETE PER ENGINEERING DRAWING AND FUSION WELD AS REQUIRED.
 1. MATERIAL: SEE COMPONENTS
- NOTES: UNLESS OTHERWISE SPECIFIED



Eckert & Ziegler
Isotope Products

VALENCIA, CALIFORNIA 91355

THIS DRAWING IS THE PROPERTY OF ECKERT & ZIEGLER ISOTOPE PRODUCTS AND MAY NOT BE USED, REPRODUCED, PUBLISHED OR DISCLOSED TO OTHERS WITHOUT EXPRESS AUTHORIZATION BY ECKERT & ZIEGLER ISOTOPE PRODUCTS.

P/N A3224-XYZ; ASSEMBLY

CAGE CODE	32993	DRAWING SIZE	LETTER	DRAWN	IT	TITLE	GFS INDUSTRIAL PHOTON SOURCE
	UNLESS OTHERWISE SPECIFIED DIMENSIONS ARE IN INCH SIZES. METRIC UNITS [mm] ARE IN MILLIMETERS.		ME/CHECKER		JR		SERIES TITLE
TOLERANCES (UNLESS OTHERWISE SPECIFIED)		ANGULAR TOLERANCE OF 0°±30'		ENGINEER	IT	INDUSTRIAL SOURCES , GFS AND XFB	
X.XXX ± .002 INCH		FRACTIONAL DIMENSIONS ± 1/32"		SCALE	10:1	DRAWING NO.	3224
X.XX ± .005 INCH		INCH				REV	S
X.X ± .03 INCH		INCH				SHEET	3 OF 5
X. ± .1 INCH		INCH SURFACE ROUGHNESS μ INCH MAX					

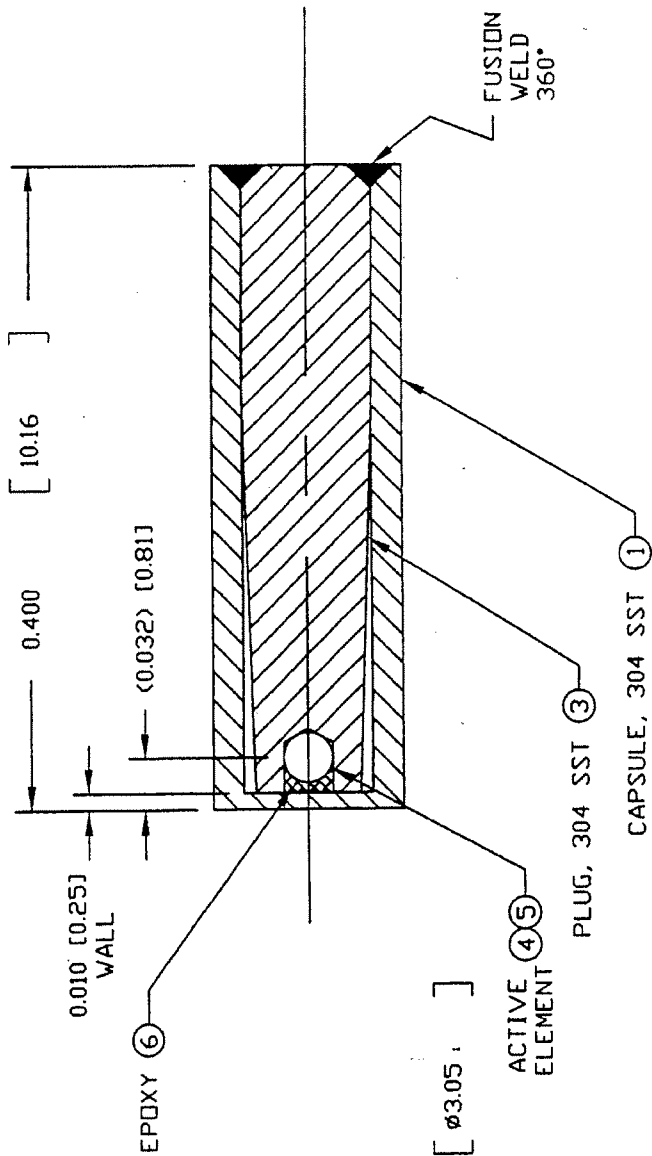

SECTION A-A

3807 ASSEMBLY

2. METRIC DIMENSIONS [mm] ARE IN MILLIMETERS.
 1. ASSEMBLE COMPLETE PER ENGINEERING DRAWING.
 NOTES: UNLESS OTHERWISE SPECIFIED

Isotope Products Laboratories
 An Eckert & Ziegler Company
 VALENCIA, CALIFORNIA 91355

DRAWN EW 12-JAN-87		TITLE CO-57 SOURCE	
PRE-CHECKER KA 16-JAN-87		AMERSHAM X.101/2 CAPSULE	
ENGR EW 12-JAN-87		DRAWING NO. 3807	
SCALE NONE	SIZE A	SERIES TITLE INDUSTRIAL SOURCES, CUSTOM	REV B
		SHEET 3 OF 6	



U.S. Department of
Transportation

**Pipeline and
Hazardous Materials
Safety Administration**

East Building, PHH-23
1200 New Jersey Ave, SE
Washington, D.C. 20590

CERTIFICATE NUMBER: USA/0516/S-96

ORIGINAL REGISTRANT(S) :

Eckert & Ziegler Isotope Products
24937 Avenue Tibbitts
Valencia, CA, 91355
USA