



U.S. Department
of Transportation
**Pipeline and
Hazardous Materials
Safety Administration**

**COMPETENT AUTHORITY CERTIFICATION
FOR A TYPE B(U)
RADIOACTIVE MATERIALS PACKAGE DESIGN
CERTIFICATE USA/0591/B(U)-96, REVISION 11**

East Building, PHH-23
1200 New Jersey Avenue Southeast
Washington, D.C. 20590

**REVALIDATION OF UNITED KINGDOM COMPETENT AUTHORITY
CERTIFICATE GB/3750A/B(U)-96**

This certifies that the radioactive material package design described is hereby approved for use within the United States for import and export shipments only. Shipments must be made in accordance with the applicable regulations of the International Atomic Energy Agency¹ and the United States of America².

1. Package Identification - Reviss Model No. R7008, Serial Numbers:
GB/3750/01, GB/3750/02, GB/3750/03, GB/3750/04, GB/3750/05,
GB/3750/06, GB/3750/07, GB/3750/08, GB/3750/09, GB/3750/17,
GB/3750/18, GB/3750/19, and GB/3750/20.
2. Package Description and Authorized Radioactive Contents - as described
in United Kingdom Certificate of Competent Authority GB/3750A/B(U)-96,
Revision 5 (attached).
3. General Conditions -
 - a. Each user of this certificate must have in his possession a copy of this certificate and all documents necessary to properly prepare the package for transportation. The user shall prepare the package for shipment in accordance with the documentation and applicable regulations.
 - b. Each user of this certificate, other than the original petitioner, shall register his identity in writing to the Office of Hazardous Materials Technology, (PHH-23), Pipeline and Hazardous Materials Safety Administration, U.S. Department of Transportation, Washington D.C. 20590-0001.
 - c. This certificate does not relieve any consignor or carrier from compliance with any requirement of the Government of any country through or into which the package is to be transported.

¹ "Regulations for the Safe Transport of Radioactive Material, 1996 Edition (Revised), No. TS-R-1 (ST-1, Revised)," published by the International Atomic Energy Agency(IAEA), Vienna, Austria.

² Title 49, Code of Federal Regulations, Parts 100-199, United States of America.

CERTIFICATE USA/0591/B(U)-96, REVISION 11

- d. Records of Quality Assurance activities required by Paragraph 310 of the IAEA regulations¹ shall be maintained and made available to the authorized officials for at least three years after the last shipment authorized by this certificate. Consignors in the United States exporting shipments under this certificate shall satisfy the applicable requirements of Subpart H of 10 CFR 71.
4. Special Conditions -
 - a. Authorized radioactive contents must be in special form approved under the IAEA Regulations for the Safe Transport of Radioactive Materials.
 - b. The contents must be limited in decay heat such that the maximum source temperature does not exceed 525 degrees centigrade under normal conditions of transport. The assessment of source temperature should be based on air being present in the cask cavity and in the shield region cavity.
 - c. Authorized contents for air transport are restricted in accordance with paragraph 416 of the IAEA regulations cited by this certificate.
 5. Marking and Labeling - The package shall bear the marking USA/0591/B(U)-96 in addition to other required markings and labeling.
 6. Expiration Date - This certificate expires on June 30, 2020.

CERTIFICATE USA/0591/B(U)-96, REVISION 11

This certificate is issued in accordance with paragraph 808 of the IAEA Regulations and Section 173.473 of Title 49 of the Code of Federal Regulations, in response to the May 12, 2016 petition by Reviss Services, Chesham, Buckinghamshire, England, , and in consideration of other information on file in this Office.

Certified By:



Jun 03 2016

(DATE)

 Dr. Magdy El-Sibaie
Associate Administrator for Hazardous Materials Safety

Revision 11 - Issued to endorse U.K. Certificate of Approval No. GB/3750A/B(U)-96, Issue 5, with a restricted heat load and requirement that contents be in special form.



**CERTIFICATE OF APPROVAL OF PACKAGE DESIGN
FOR THE CARRIAGE OF RADIOACTIVE MATERIAL**

This is to certify that for the purposes of the Regulations of the International Atomic Energy Agency

- The Competent Authority of Great Britain in respect of inland surface transport, being the Office for Nuclear Regulation;
- The Competent Authority of the United Kingdom of Great Britain and Northern Ireland in respect of sea transport, being the Secretary of State for Transport;
- The Competent Authority of the United Kingdom of Great Britain and Northern Ireland in respect of air transport, being the Civil Aviation Authority; and
- The Competent Authority of Northern Ireland in respect of road transport, being the Department of the Environment Northern Ireland

approve the package design specified in Section 1 of this certificate, as submitted for approval by REVISS Services (UK) Limited (see Section 5)

as: Type B(U)

by: All modes.

Packaging identification: R7008

Packages manufactured to this design meet the requirements of the regulations and codes on page 2, relevant to the mode of transport, subject to the following general condition and to the conditions in the succeeding pages of this certificate.

In the event of any alteration in the composition of the package, the package design, the management system(s) associated with the package or in any of the facts stated in the application for approval, this certificate will cease to have effect unless the Competent Authority is notified of the alteration and the Competent Authority confirms the certificate notwithstanding the alteration.

Expiry Date: This certificate cancels all previous revisions and is valid until the end of June 2020 (see Section 5).

COMPETENT AUTHORITY IDENTIFICATION MARK: GB/3750A/B(U)-96

Signature:

Date of Issue: 29 April 2016

Steve Vinton, Transport Delivery Lead
Office for Nuclear Regulation
Redgrave Court, Merton Road
Bootle, Merseyside
L20 7HS

on behalf of the Office for Nuclear Regulation; and the Secretary of State for Transport; the Civil Aviation Authority; and the Department of the Environment Northern Ireland.

This certificate does not relieve the consignor from compliance with any requirement of the government of any country through or into which the package will be transported.

REGULATIONS GOVERNING THE TRANSPORT OF RADIOACTIVE MATERIALS

INTERNATIONAL

International Atomic Energy Agency (IAEA)

SSR-6 Regulations for the Safe Transport of Radioactive Material 2012 Edition

United Nations Economic Commission for Europe (UNECE)

European Agreement concerning the International Carriage of Dangerous Goods by Road (ADR) 2015 Edition

Intergovernmental Organisation for International Carriage by Rail (OTIF)

Regulations concerning the International Carriage of Dangerous Goods by Rail (RID) 2015 Edition

International Maritime Organization (IMO)

International Maritime Dangerous Goods (IMDG) Code 2014 Edition incorporating Amendment 37-14

International Civil Aviation Organization (ICAO)

Technical Instructions for the Safe Transport of Dangerous Goods by Air 2015-2016 Edition

UNITED KINGDOM

ROAD

GREAT BRITAIN ONLY:

The Energy Act 2013 (2013 c. 32); The Carriage of Dangerous Goods and Use of Transportable Pressure Equipment Regulations 2009 (SI 2009 No. 1348); The Carriage of Dangerous Goods and Use of Transportable Pressure Equipment (Amendment) Regulations 2011 (SI 2011 No. 1885); The Energy Act 2013 (Office for Nuclear Regulation) (Consequential Amendments, Transitional Provisions and Savings) Order 2014 (SI 2014 No. 469)

NORTHERN IRELAND ONLY:

The Carriage of Dangerous Goods and Use of Transportable Pressure Equipment Regulations (Northern Ireland) 2010, SR 2010 No 160; The Carriage of Dangerous Goods and Use of Transportable Pressure Equipment (Amendment) Regulations (Northern Ireland) 2011, No 365

RAIL

GREAT BRITAIN ONLY:

The Energy Act 2013 (2013 c. 32); The Carriage of Dangerous Goods and Use of Transportable Pressure Equipment Regulations 2009 (SI 2009 No. 1348); The Carriage of Dangerous Goods and Use of Transportable Pressure Equipment (Amendment) Regulations 2011 (SI 2011 No. 1885); The Energy Act 2013 (Office for Nuclear Regulation) (Consequential Amendments, Transitional Provisions and Savings) Order 2014 (SI 2014 No. 469)

SEA

British registered ships and all other ships whilst in United Kingdom territorial waters:

The Merchant Shipping Act 1995 (1995 c. 21); The Merchant Shipping (Dangerous Goods and Marine Pollutants) Regulations 1997 (SI 1997 No. 2367); Merchant Shipping Notice MSN 1854 (M) The Carriage of Dangerous Goods and Marine Pollutants in Packaged Form: Amendment 37-14 to the International Maritime Dangerous Goods (IMDG) Code

AIR

The Air Navigation Order 2009 (SI 2009 No. 3015); The Air Navigation (Dangerous Goods) Regulations 2002 (SI 2002 No. 2786); The Air Navigation (Dangerous Goods) (Amendment) Regulations 2015 (SI 2015 No. 970)

1. DESIGN SPECIFICATION

Package Design

- 1.1 The package design specification shall be in accordance with REVISS Services (UK) Limited Safety Report, UK Type B(U) Package Design Approval Application for the R7008 Transport Container, reference R7008BU Issue 6 dated 21 March 2013, REVISS letter to ONR dated 14 May 2015, and modifications to the package design approved by the authorities named on page 1 of this certificate under the established modifications procedure.

Design Drawings

- 1.2 The design is specified in the following drawings.

Design No.	Title (number of components)	Drawing / Drawing List	Issue
3750	Outer – Pallet & Cage (one)	Drawing List QS7008	5
	Inner – Body & Closure (one)		
Various according to capsule design	Innermost – Basket and any IAEA Special Form Material Capsule	Depending on capsule design	

Package Description and Materials of Manufacture

- 1.3 The packaging is a depleted uranium shielded flask mounted on a pallet and enclosed within a wire mesh covered cage. Apart from the shielding all constructional materials, including the fasteners, are austenitic stainless steel. The depleted uranium shielding is totally enclosed and sealed within the stainless steel structure. See Appendix 1 for package illustration.

Package Dimension and Weights

- 1.4 Nominal dimensions: 1360mm x 1360mm x 1370mm
1.5 Maximum authorised gross weight: 3573kg

Authorised Contents

- 1.6 The authorised radioactive contents are either Cobalt 60 or Caesium 137 with the following details:

Radionuclide	Physical State	Chemical Composition or State	Maximum Activity
⁶⁰ Co	Solid - Special Form	Metal	12.6PBq
¹³⁷ Cs		Chloride	5.55PBq

Restriction on Contents

- 1.7 The content must be encapsulated in approved IAEA Special Form Capsules.
1.8 The maximum content weight including basket is 27kg.
1.9 The total rate of heat generation shall not exceed 5.23kW.

- 1.10 The carriage of ^{60}Co by air with an activity above 1.2PBq and up to the maximum specified above is only allowed with permission from the air transport authority of each national air space entered or transited. In the UK, this is the Civil Aviation Authority (CAA).

Containment System

- 1.11 The containment system is the Special Form Capsule(s).

2. USE OF PACKAGE

Information Provided in Safety Report on Use of Packaging

- 2.1 The packaging shall be used and handled in accordance with Section 4 of the document referred to in paragraph 1.1 and the latest issue of the REVISS Services (UK) Limited Operating and Maintenance Instructions for the R7008 Transport Container (GB 3750A) OP316.
- 2.2 The packaging shall be maintained in accordance with Section 7.3 of the document referred to in paragraph 1.1 and the latest issue of the REVISS Services (UK) Limited Operating and Maintenance Instructions for the R7008 Transport Container (GB 3750A) OP316.

Actions Prior to Shipment

- 2.3 Administrative controls shall ensure that the contents are in accordance with Section 1 of this certificate, and that the consignor and consignee hold a copy of the instructions on the use of the packaging.
- 2.4 When the sources, together with the capsule holder, are loaded, they shall be located in the source cavity in such a way as to prevent gross movement during routine, normal and accident conditions of transport.
- 2.5 The container should be operated by personnel suitable trained in the relevant operating procedures.
- 2.6 When loaded with more than 10.8PBq ^{60}Co , the package must be transported under "Exclusive Use" conditions.

Supplementary Operational Controls

- 2.7 The package shall not be sheeted over or over-stowed by loose cargo.

Emergency Arrangements

- 2.8 Before shipment takes place, suitable emergency plans will have been drawn up, copies of which shall be supplied to the GB Competent Authority on demand.
- 2.9 Within Great Britain, if the consignor's own, or other approved emergency plans, cannot be initiated for any reason, then the police shall be informed immediately and requested to call NAIR (National Arrangements for Incidents involving Radioactivity).

3. MANAGEMENT SYSTEMS

- 3.1 The management system(s) assessed as adequate in relation to this design by the authorities named on page 1 of this certificate, at the date of issue, are as specified in REVISS Services (UK) Limited Safety Report, UK Type B(U) Package Design Approval Application for the R7008 Transport Container, reference R7008BU Issue 6 dated 21 March 2013, referred to in paragraph 1.1 above, and comprise the following:
- REVISS Services' Quality Assurance Manual QM Issue 10 dated 1 July 2015
- 3.2 No alteration may be made to any management system confirmed as adequate in relation to this design, unless:

- a) the authorities named on page 1 of this certificate have confirmed the amended management system is adequate prior to implementation or use; or
 - b) the alteration falls within the agreed change control procedures set out in the management system(s).
- 3.3 Other management systems for design, testing, manufacture, documentation, use, maintenance, inspection, transport and in-transit storage operations may be used providing they comply with international, national or other standards for management systems agreed as acceptable by the authorities named on page 1 of this certificate.

4. ADMINISTRATIVE INFORMATION

Related Approvals – Not applicable

Shipment Approval – Not applicable

Packaging Serial Numbers

- 4.1 This design approval applies only to packaging serial numbers 3750/01 to 09 and 3750/17 to 3750/20.
- 4.2 For the purpose of compliance with ADR / RID, the owner of the packaging shall be responsible for informing ONR of the serial number of each packaging manufactured to this design.

Additional Technical Data / Information – Not applicable

5. CERTIFICATE STATUS

Design approval issued to:

REVISS Services (UK) Limited
179 Brook Drive
Milton Park
Abingdon
Oxfordshire
OX14 4SD
UK

Issue / Revision Number	Date of Issue	Date of Expiry	Reason for Revision
1	22 August 2003	31 August 2006	Design Approval issued under new regulations
2	15 June 2006	31 August 2009	Certificate renewal for a further 3 years
3	20 May 2009	31 May 2014	Certificate renewal for a further 5 years
NA	28 February 2014	31 May 2015	Extension for a further year of Issue 3. Extension Letter ref TRIM 2014/85363
4	17 June 2015	30 June 2020	Certificate renewal for a further 5 years
5	29 April 2016	30 June 2020	Certificate limited by identifying packaging serial numbers (Applicant Modification No 7)

APPENDIX 1 – PACKAGE ILLUSTRATION

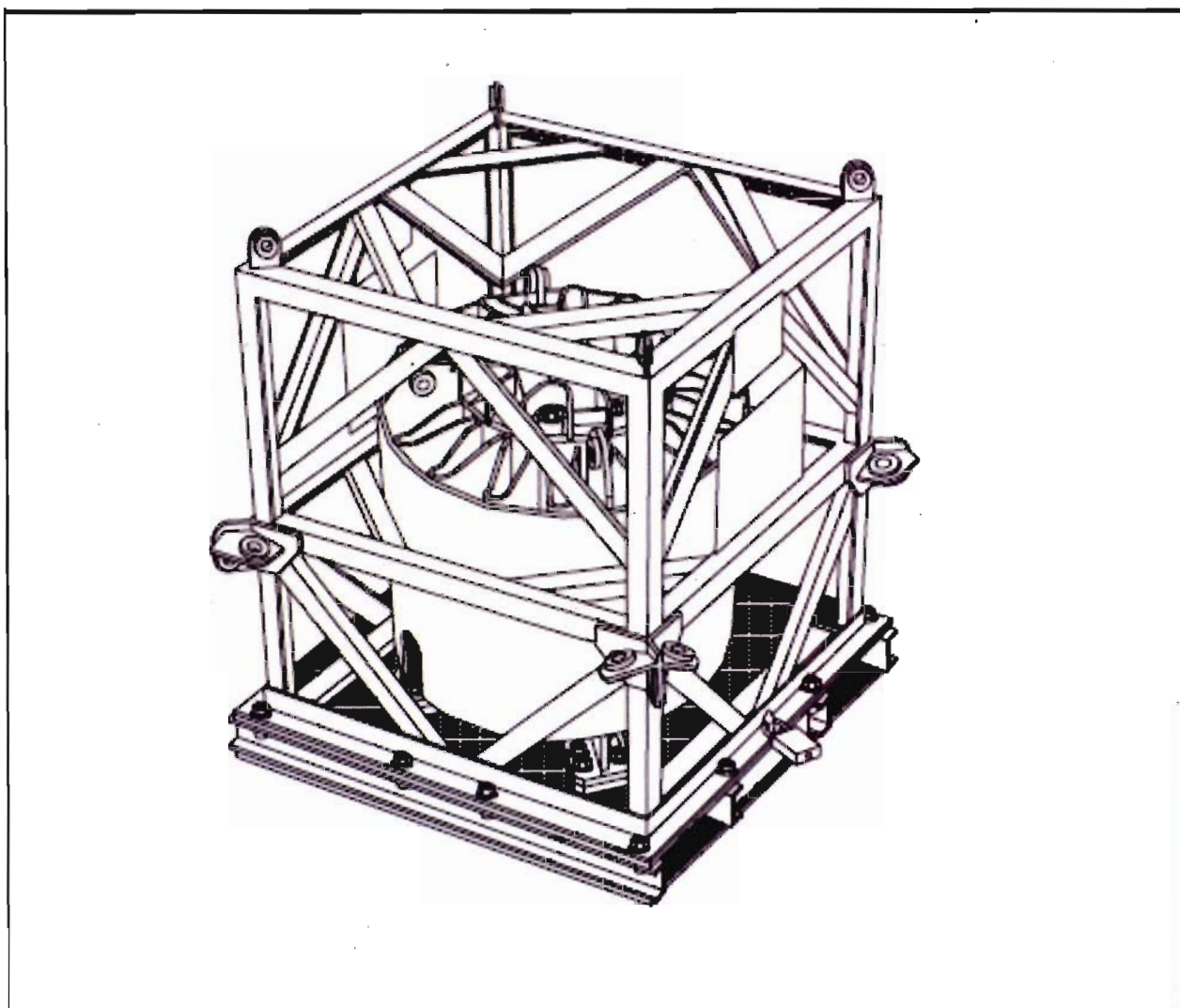

R7008 Transport Container



U.S. Department
of Transportation

East Building, PHH-23
1200 New Jersey Avenue SE
Washington, D.C. 20590

**Pipeline and
Hazardous Materials
Safety Administration**

CERTIFICATE NUMBER: USA/0591/B(U)-96, Revision 11

ORIGINAL REGISTRANT(S):

Mr. David Rogers
Transport, Packaging and Transport Manager
Revis Services
6 Chiltern Court
Asheridge Road
Chesham
Buckinghamshire, England HP5 2PX
Great Britain

REGISTERED USER(S):

Ms. Lori Podolak
Manager, Regulatory Affairs/Quality Assurance
QSA Global, Inc.
40 North Avenue
Burlington, MA 01803

Ms. Mary Shepherd
Vice President
J.L. Shepherd & Associates
1010 Arroyo Ave.
San Fernando, 91340-1822
USA

Mr. John Miller
Radiation Safety Officer
International Isotopes Inc.
4137 Commerce Circle
Idaho Falls, 83401
USA

Mr. Michael Fuller
Regulatory Compliance Associate
QSA Global, Inc.
40 North Avenue
Burlington, MA 01803

Mr. Carlos Martinez
Program Engineer
GE-Hitachi Nuclear Energy Americas, LLC
6705 Vallecitos Rd
Sunol, 94586
USA

Mr. C. Joseph Harless
Director, Radiation Safety
Sterigenics
10811 Withers Cove Park Drive
Charlotte, 28278
USA

Luc Desgagne
Senior Licensing Coordinator
Nordion (Canada) Inc.
447 March Road
Ottawa, K2K 1X8
Canada

Jackie Kavanagh
Manager, Facility & Transportation Licensing
Nordion (Canada) Inc.
447 March Road
Ottawa, K2K 1X8
Canada

Mr. Anatoly Khoreshko
Director of Radioisotope Plant
Mayak Production Association
FSUE Mayak Production Association
31 Lenin Street
Ozyorsk, Chelyabinsk Region 456780
Russian Federation

Mr. Nengwu Huang
Chengdu Gaotong Isotope Co., Ltd.
Science & Technology Development Building B
No.28 South Thrid Section
Yihuan Road
Chengdu, 610041
CHINA

Mr. Yu-Lung “Dan” Cheng
Majestic Superior Logistics Inc
3100 S 176th Street
Suite 100
Seatac, 98188
USA

Dr. David Coppel
Quality & Regulatory Manager
Mayak Production Association
Suite F
Breakspear Park
Breakspear Way
Hemel, Hempstead HP2 4TZ
United Kingdom

Mr. Juan G. Ayala
Regulatory Compliance
GE-Hitachi Nuclear Energy Americas, LLC
6705 Vallecitos Road
Sunol, CA 94586