



U.S. Department
of Transportation

Pipeline and
Hazardous Materials
Safety Administration

East Building, PHH-23
1200 New Jersey Ave, SE
Washington, D.C. 20590

IAEA CERTIFICATE OF COMPETENT AUTHORITY
SPECIAL FORM RADIOACTIVE MATERIALS

CERTIFICATE USA/0673/S-96, REVISION 4

This certifies that the sources described have been demonstrated to meet the regulatory requirements for special form radioactive material as prescribed in the regulations of the International Atomic Energy Agency¹ and the United States of America² for the transport of radioactive material.

1. Source Identification - QSA Global, Inc. Models XN30/0, XN30/1, and XN30/2 (All models manufactured on or after May 22, 1980).
2. Source Description - Cylindrical single encapsulations made of stainless steel and tungsten inert gas or laser seal welded. Approximate exterior dimensions are 6.0 mm (0.24 in.) in diameter and 10.3 mm (0.41 in.) in length. Minimum wall thickness is 0.47 mm (0.02 in.). Construction shall be in accordance with attached AEA Technology QSA, Inc. Drawing No. RBA10251, Rev. A (2 pages).
3. Radioactive Contents - No more than either 4.44 GBq (120.0 mCi) of Cesium-137 (Model XN30/0), or 18.5 GBq (500.0 mCi) of Americium-241 (Model XN30/1), or 18.5 MBq (500.0 uCi) of Cobalt-60 (Model XN30/2). The Cs-137 is either chemically bonded within a borosilicate glass polymer or is in the form of a solid resin bead. The Am-241 is in the form of an oxide mixed with a beryllium powder that is then pressed into a solid pellet. The Co-60 is in the form of a metal.
4. Management System Activities - Records of Management System activities required by Paragraph 306 of the IAEA regulations shall be maintained and made available to the authorized officials for at least three years after the last shipment authorized by this certificate. Consignors in the United States exporting shipments under this certificate shall satisfy the requirements of Subpart H of 10 CFR 71.

¹ "Regulations for the Safe Transport of Radioactive Material, 2012 Edition, No. SSR-6" published by the International Atomic Energy Agency (IAEA), Vienna, Austria.

² Title 49, Code of Federal Regulations, Parts 100-199, United States of America.

CERTIFICATE USA/0673/S-96, REVISION 4

5. Expiration Date - This certificate expires on August 31, 2023. Previous editions which have not reached their expiration date may continue to be used.

This certificate is issued in accordance with paragraph(s) 804 of the IAEA Regulations and Section 173.476 of Title 49 of the Code of Federal Regulations, in response to the August 1, 2018 petition by QSA Global, Inc., Burlington, MA, and in consideration of other information on file in this Office.

Certified By:



September 04,
2018

 William Schoonover
Associate Administrator for Hazardous
Materials Safety

(DATE)

Revision 4 - Issued to extend the expiration date.

ITEM	DESCRIPTION	QTY.
1	BODY STAIN. STL.	1
2	LID STAIN. STL.	1
3	CERAMIC FIBRE PACKING A/R	1
4	SPACER ALUMINIUM ALLOY	1
5	ACTIVE MATERIAL A/R	1

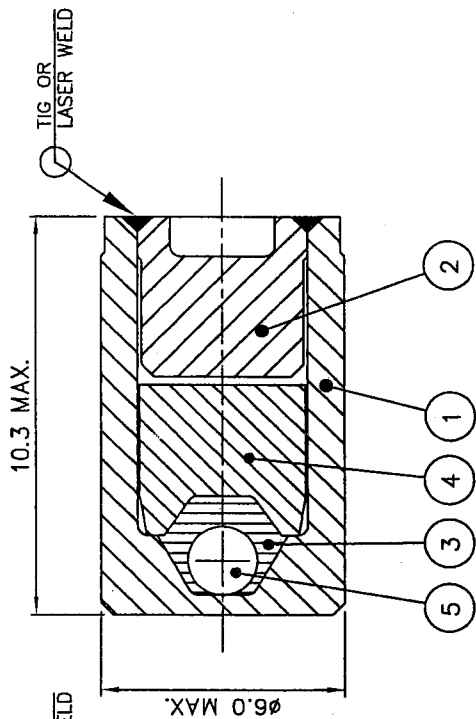

XN30/0

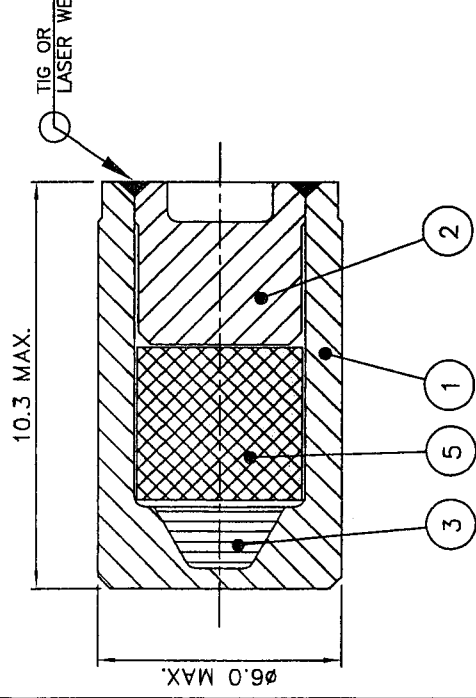

XN30/1

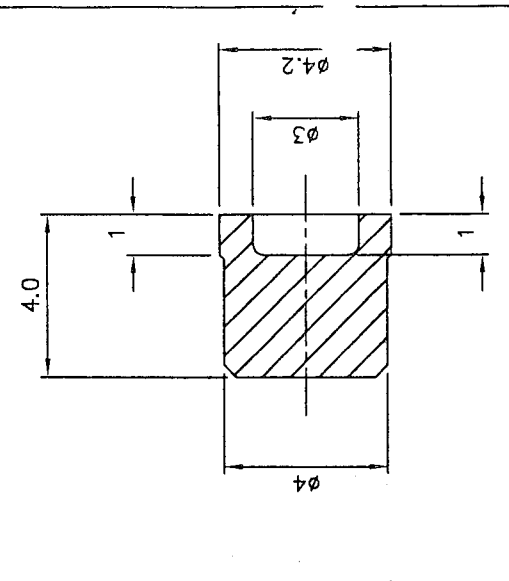

ITEM 2

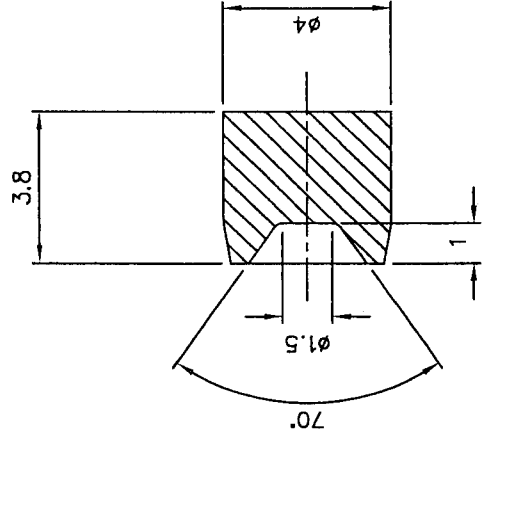

ITEM 4

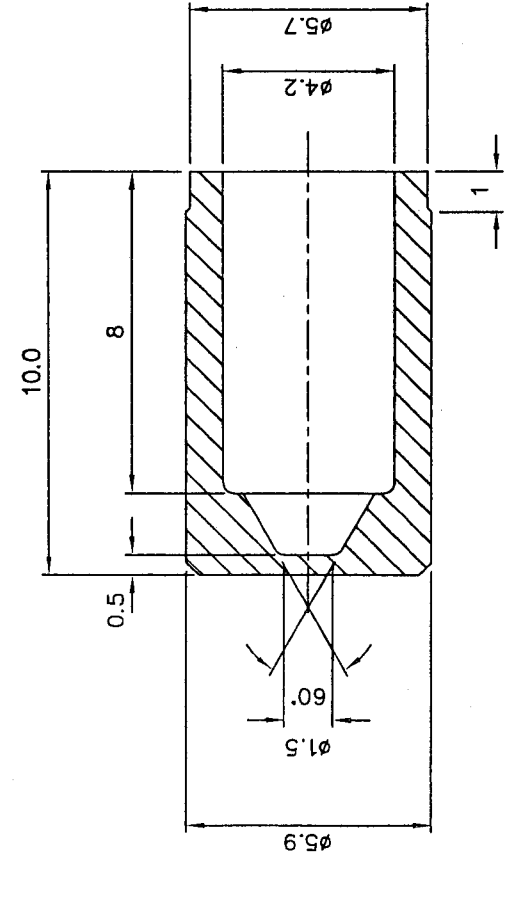

ITEM 1



APPROVALS	
<i>R. J. Moore</i>	16 Apr 07
<i>L. P. ...</i>	21 Apr 07

DIMENSIONS IN MILLIMETERS
UNLESS OTHERWISE STATED TOLERANCES:

X	±0.5	INTERNAL	∇
X.X	±0.1	EXTERNAL	∇
X.XX	±0.05		
ANGULAR	±5°		

TITLE XN30/0, /1 & /2 CAPSULE ASSEMBLY	
SIZE A	DWG. NO. RBA10251
SCALE: NONE	SHEET 1 OF 2
REV	A

ERF # 828

ITEM	DESCRIPTION	QTY.
6	BODY STAIN. STL.	1
7	LID STAIN. STL.	1
8	CERAMIC FIBRE PACKING	A/R
9	ACTIVE MATERIAL	A/R

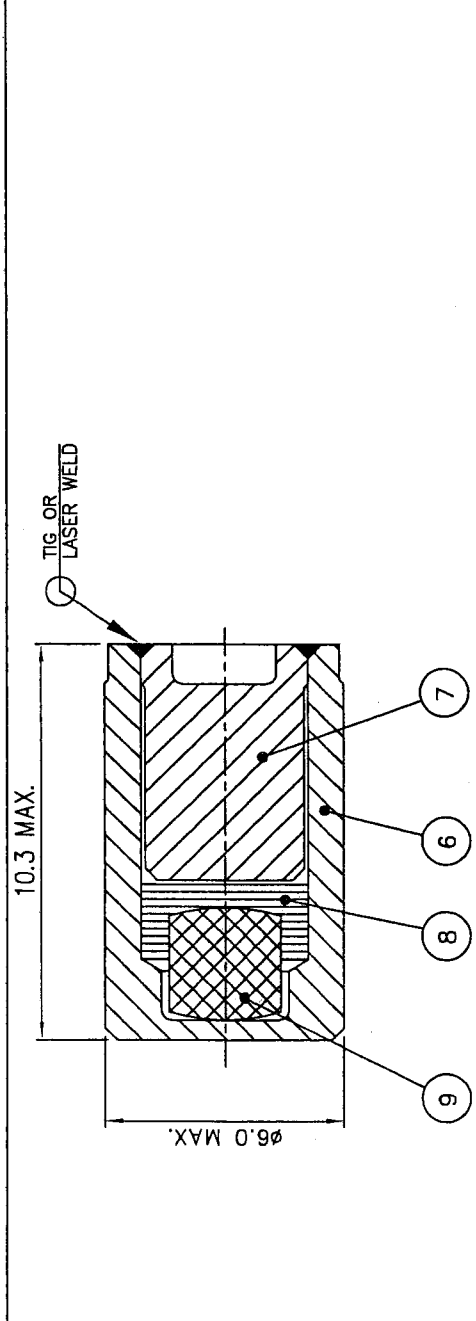

XN30/2

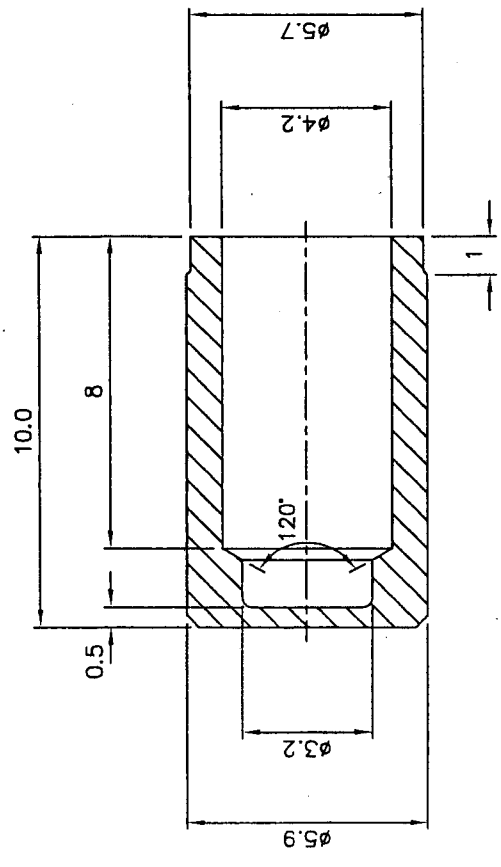

ITEM 6

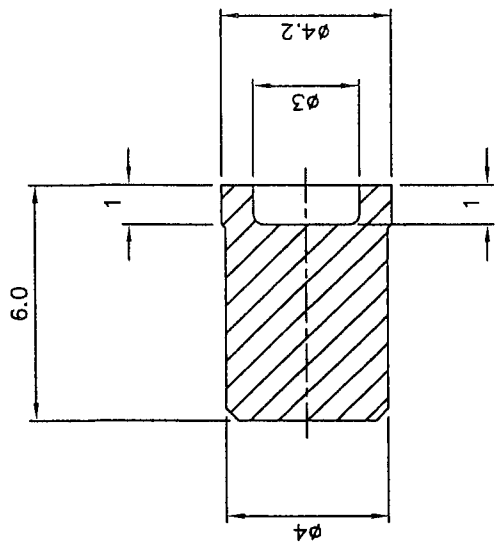

ITEM 7

		DESCRIPTIVE DRAWING	
APPROVALS <i>D. Winger</i> 11/11/07 <i>L. P. DeLid</i> 2/1/07		TITLE XN30/0, /1 & /2 CAPSULE ASSEMBLY	
DIMENSIONS IN MILLIMETERS UNLESS OTHERWISE STATED TOLERANCES: X ±0.5 XX ±0.1 XXX ±0.05 ANGULAR ±5°		SIZE A	
INTERNAL <input checked="" type="checkbox"/> EXTERNAL <input checked="" type="checkbox"/>		SCALE: NONE	
ERF # 828		DWG. NO. RBA10251	
		SHEET 2 OF 2	
		REV A	



U.S. Department of
Transportation

**Pipeline and
Hazardous Materials
Safety Administration**

East Building, PHH-23
1200 New Jersey Ave, SE
Washington, D.C. 20590

CERTIFICATE NUMBER: USA/0673/S-96

ORIGINAL REGISTRANT(S) :

QSA Global, Inc.
30 North Avenue
Burlington, MA, 01803
USA

Troxler Electronic Laboratories
P.O. Box 12057
3008 Cornwallis Road
Research Triangle Park, NC, 27709
USA