



U.S. Department  
of Transportation

Pipeline and  
Hazardous Materials  
Safety Administration

East Building, PHH-23  
1200 New Jersey Ave, SE  
Washington, D.C. 20590

IAEA CERTIFICATE OF COMPETENT AUTHORITY  
SPECIAL FORM RADIOACTIVE MATERIALS

CERTIFICATE USA/0812/S-96, REVISION 1

This certifies that the sources described have been demonstrated to meet the regulatory requirements for special form radioactive material as prescribed in the regulations of the International Atomic Energy Agency<sup>1</sup> and the United States of America<sup>2</sup> for the transport of radioactive material.

1. Source Identification - Source Production & Equipment Company, Inc. G/SR Series source capsules.
2. Source Description - Cylindrical double or triple encapsulations. The double encapsulation is constructed of a vanadium inner encapsulation sealed by Laser Beam Welding (LBW) with either a Type 316 stainless steel or a titanium outer encapsulation that is sealed by either Gas Tungsten Arc Welding (GTAW) or LBW. Approximate outer dimensions of the double encapsulation (G/SR-INNER) are 4.9 mm (0.19 in.) in diameter and 6.85 mm (0.27 in.) in length. The triple encapsulations consist of a G/SR-INNER double encapsulation installed in a Type 316 stainless steel encapsulation that is sealed by GTAW or LBW and has either a single tab on one end or a tab on each end. Approximate outer dimensions of the triple encapsulations are 6.88 mm (0.27 in.) in diameter and 22.0 mm (0.87 in.) in length (G/SR-18) or 28.7 mm (1.13 in.) in length (G/SR-17). Construction shall be in accordance with attached Source Production & Equipment Co., Inc. Drawing No. BS1706 Rev. 3.
3. Radioactive Contents - No more than 5.55 TBq (150 Ci) of Selenium-75. The Se-75 is in a solid metal alloy.

---

<sup>1</sup> "Regulations for the Safe Transport of Radioactive Material, 2012 Edition, No. SSR-6" published by the International Atomic Energy Agency (IAEA), Vienna, Austria.

<sup>2</sup> Title 49, Code of Federal Regulations, Parts 100-199, United States of America.

**CERTIFICATE USA/0812/S-96, REVISION 1**

4. Management System Activities - Records of Management System activities required by Paragraph 306 of the IAEA regulations shall be maintained and made available to the authorized officials for at least three years after the last shipment authorized by this certificate. Consignors in the United States exporting shipments under this certificate shall satisfy the requirements of Subpart H of 10 CFR 71.
  
5. Expiration Date - This certificate expires on April 30, 2024. Previous editions which have not reached their expiration date may continue to be used.

This certificate is issued in accordance with paragraph(s) 804 of the IAEA Regulations and Section 173.476 of Title 49 of the Code of Federal Regulations, in response to the April 22, 2019 petition by Source Production and Equipment Company, Inc., St. Rose, LA, and in consideration of other information on file in this Office.

Certified By:



William Schoonover  
Associate Administrator for Hazardous  
Materials Safety

May 03, 2019  
(DATE)

Revision 1 - Issued to extend the expiration date, and to eliminate Selenium-75 in elemental form.

REVISIONS			
REV	DESCRIPTION	DATE	APPROVED

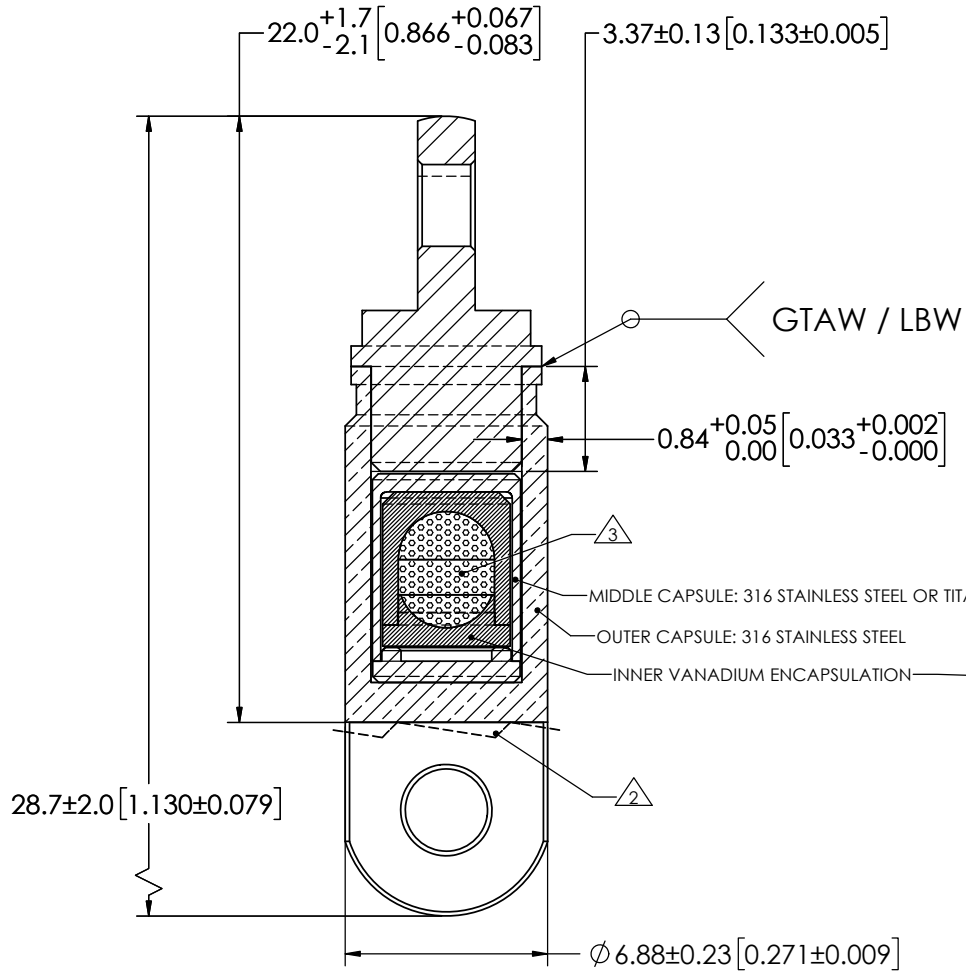

**TRIPLE ENCAPSULATED  
G/SR-17 & G/SR-18**

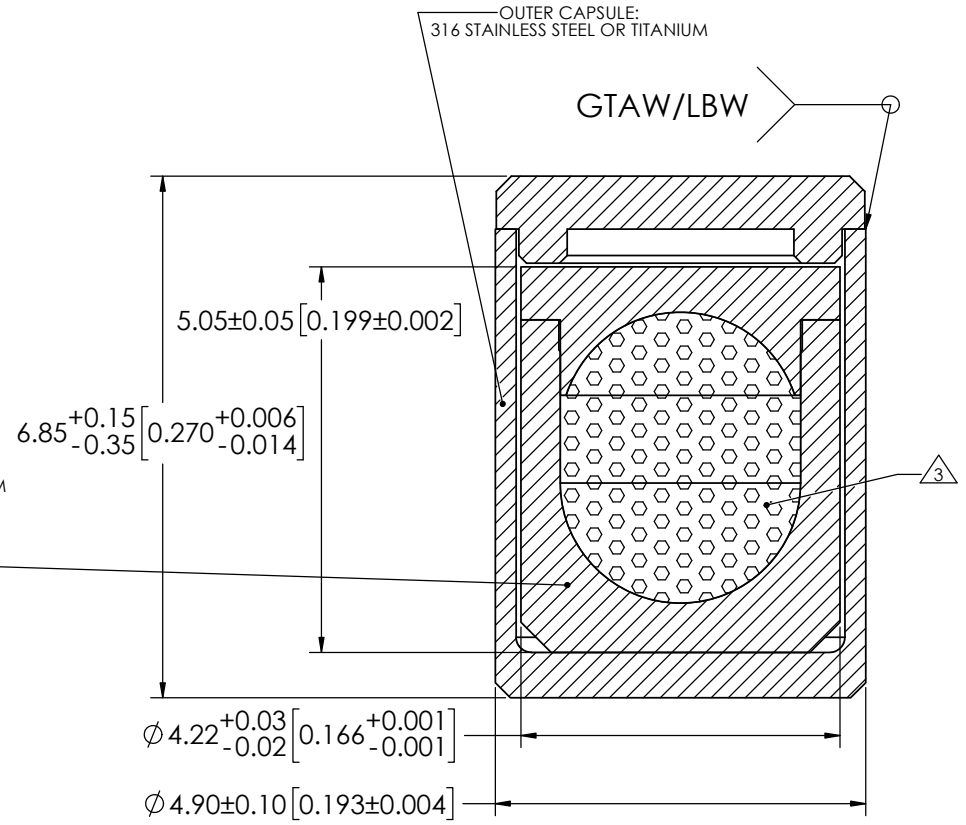

**DOUBLE ENCAPSULATED  
G/SR-INNER**

**NOTES:**

- DIMENSIONS IN [BRACKETS] ARE INCHES.
- LOWER CONNECTION TAB IS OPTIONAL. G/SR-17 HAS TWO TABS. G/SR-18 HAS A SINGLE TAB. BODY OF NON TABBED BOTTOM WILL BE FLAT AND CHAMFERED AS NECESSARY.
- RADIOACTIVE CONTENTS TO BE A MAXIMUM OF 125mg OF SELENIUM METAL ALLOY.

UNLESS OTHERWISE SPECIFIED DIMENSIONS ARE MILLIMETERS TOLERANCES ARE:  AS SHOWN	APPROVALS	DATE	SOURCE PRODUCTION & EQUIPMENT CO., INC. 113 TEAL ST, ST. ROSE, LA 70087	
	DRAWN WKM	4/19/19	G/SR SERIES CAPSULE ASSEMBLY	
	CHECKED MQ1	MQ1	SIZE	DWG. NO.
	APPROVED MQ1	MQ1	A	BS1706
TREATMENT NONE	QA CLASS		REV	3
FINISH NONE			SCALE: NTS	BS170603
DO NOT SCALE DRAWING			SHEET 1 OF 2	

REVISIONS			
REV	DESCRIPTION	DATE	APPROVED
1-2	ALL CHANGES ARE IN MQ1.	MQ1	MQ1

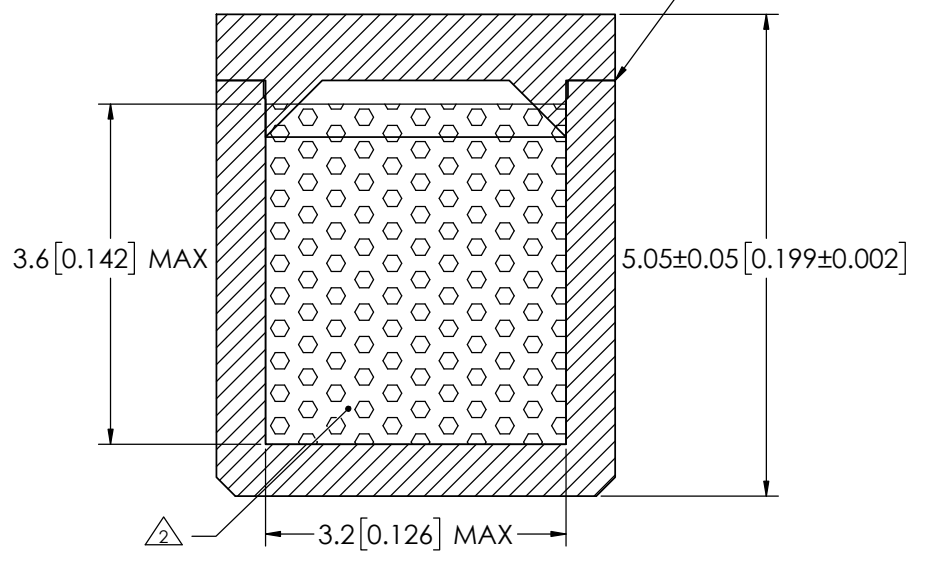
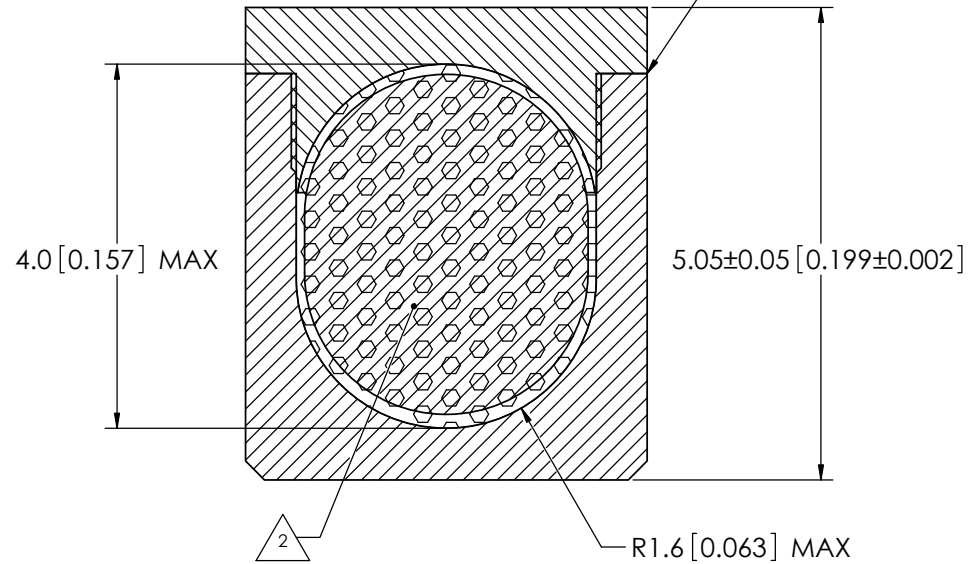
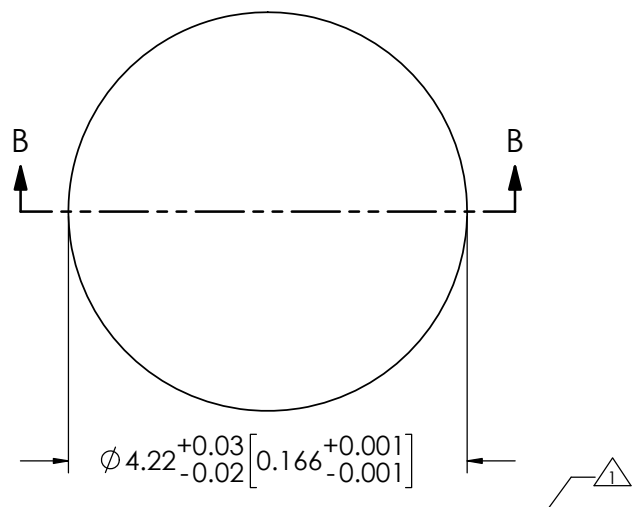
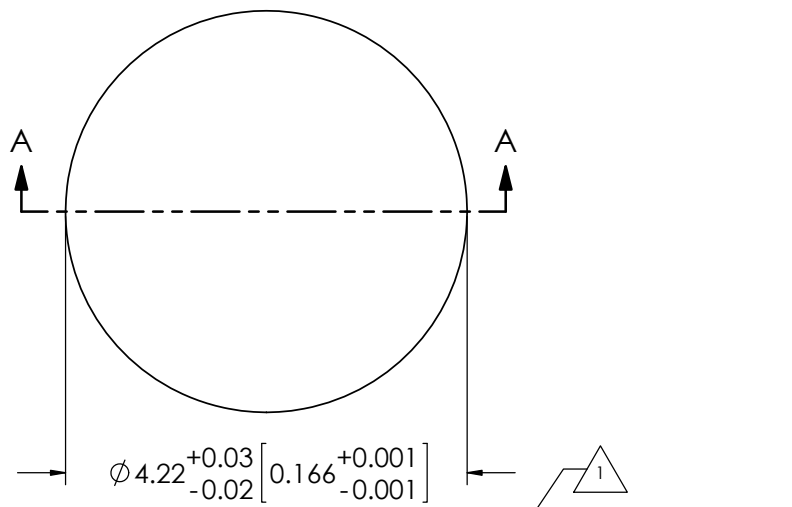

**VANADIUM SPHERICAL ENCAPSULATION**

**VANADIUM CYLINDRICAL ENCAPSULATION**

- NOTES:
- 1. LASER WELDED WITH MINIMUM 0.50 mm PENETRATION.
  - 2. CONTENTS TO BE A MAXIMUM OF 125mg SELENIUM METAL ALLOY.
  - 3. MATERIAL IS COMMERCIAL PURE (0.99) VANADIUM.
  - 4. CAPSULE MAY BE COATED WITH NICKEL, RHODIUM, OR TITANIUM ALUMINUM NITRIDE.
  - 5. DIMENSIONS IN [BRACKETS] ARE INCHES.

UNLESS OTHERWISE SPECIFIED DIMENSIONS ARE IN MILLIMETERS TOLERANCES ARE:	APPROVALS	DATE	SOURCE PRODUCTION & EQUIPMENT CO., INC. 113 TEAL ST, ST. ROSE, LA 70087	
	DRAWN WKM	4/19/19	G/SR SERIES CAPSULE ASSEMBLY	
	CHECKED MQ1	MQ1		
	APPROVED MQ1	MQ1		
TREATMENT NONE		SIZE <b>C</b>	DWG. NO. BS1706	REV <b>3</b>
FINISH NONE		SCALE: NTS	BS122403	SHEET 2 OF 2
DO NOT SCALE DRAWING	QA CLASS			



U.S. Department of  
Transportation

**Pipeline and  
Hazardous Materials  
Safety Administration**

East Building, PHH-23  
1200 New Jersey Ave, SE  
Washington, D.C. 20590

**CERTIFICATE NUMBER:** USA/0812/S-96

**ORIGINAL REGISTRANT(S) :**

Source Production and Equipment Company, Inc.  
113 Teal Street  
St. Rose, LA, 70087  
USA

Industrial Nuclear Company, Inc.  
14320 Wicks Blvd.  
San Leandro, CA, 94577  
USA