



U.S. Department  
of Transportation

Pipeline and  
Hazardous Materials  
Safety Administration

East Building, PHH-23  
1200 New Jersey Ave, SE  
Washington, D.C. 20590

**COMPETENT AUTHORITY CERTIFICATION FOR A  
TYPE B(U)  
RADIOACTIVE MATERIALS PACKAGE DESIGN  
CERTIFICATE USA/6355/B(U) , REVISION 17**

**REVALIDATION OF CANADIAN COMPETENT AUTHORITY  
CERTIFICATE CDN/2009/B(U)**

The Competent Authority of the United States certifies that the radioactive material package design described in this certificate satisfies the regulatory requirements for a Type B(U) package as prescribed in the regulations of the International Atomic Energy Agency<sup>1</sup> and the United States of America<sup>2</sup>.

1. Package Identification - MDS Nordion F-147 Transfer Case, Serial Numbers 18, 24, 26, 27, 34-36, 39-48, 50, 52, 54, and 56-60.
2. Package Description and Authorized Radioactive Contents - as described in Canadian Certificate of Competent Authority CDN/2009/B(U), 15 (attached).
3. General Conditions -
  - a. Each user of this certificate must have in his possession a copy of this certificate and all documents necessary to properly prepare the package for transportation. The user shall prepare the package for shipment in accordance with the documentation and applicable regulations.
  - b. Each user of this certificate, other than the original petitioner, shall register his identity in writing to the Office of Engineering and Research, (PHH-23), Pipeline and Hazardous Materials Safety Administration, U.S. Department of Transportation, Washington D.C. 20590-0001.
  - c. This certificate does not relieve any consignor or carrier from compliance with any requirement of the Government of any country through or into which the package is to be transported.

---

<sup>1</sup> "Regulations for the Safe Transport of Radioactive Material, 2012 Edition, No. SSR-6" published by the International Atomic Energy Agency (IAEA), Vienna, Austria.

<sup>2</sup> Title 49, Code of Federal Regulations, Parts 100-199, United States of America.

**CERTIFICATE USA/6355/B(U) , REVISION 17**

- d. Records of Management System activities required by Paragraph 306 of the IAEA regulations<sup>1</sup> shall be maintained and made available to the authorized officials for at least three years after the last shipment authorized by this certificate. Consignors in the United States exporting shipments under this certificate shall satisfy the applicable requirements of Subpart H of 10 CFR 71.
4. Marking and Labeling - The package shall bear the marking USA/6355/B(U) in addition to other required markings and labeling.
5. Expiration Date - This certificate expires on November 30, 2022. Previous editions which have not reached their expiration date may continue to be used.

This certificate is issued in accordance with paragraph(s) 820 of the IAEA Regulations and Section 173.473 of Title 49 of the Code of Federal Regulations, in response to the October 1, 2018 petition by Best Theratronics Ltd., Ottawa, Ontario, and in consideration of other information on file in this Office.

Certified By:



William Schoonover  
Associate Administrator for Hazardous  
Materials Safety

October 23, 2018  
(DATE)

Revision 17 - Issued to revalidate Canadian Package Design Approval Certificate No. CDN/2009/B(U), Revision 15.



# Certificate

**CDN/2009/B(U) (Rev. 15)**

## Transport Package Design

The transport package design identified below is certified by the Canadian Nuclear Safety Commission pursuant to paragraph 21(1)(h) of the *Nuclear Safety and Control Act* and Subsection 10(1) of the *Packaging and Transport of Nuclear Substances Regulations*, 2015 and to the 1973 Revised Edition (as amended) of the IAEA's *Regulations for the Safe Transport of Radioactive Material*.

### REGISTRATION OF USE OF PACKAGES

All users of this authorization shall register their identity in writing with the Canadian Nuclear Safety Commission prior to the first use of this authorization and shall certify that they possess the instructions necessary for preparation of the package for shipment.

### PACKAGE IDENTIFICATION

Designer: **Nordion**  
Make/Model: **F-147 Transfer Case, Serial Nos. 18, 24, 26, 27, 34-36, 39-48, 50, 52, 54, 56-60**  
Mode of Transport: **Air, Sea, Road, Rail**

### IDENTIFICATION MARK

The package shall bear the competent authority identification mark "**CDN/2009/B(U)**".

### PACKAGE DESCRIPTION

The packaging consists of a type F-147 transfer case in conjunction with a fire shield as shown on Drawing Nos. TC3-17 (Rev. J) and D93-V-46 (Rev. E). The containment system consists of welded capsules and the 250 mm thick steel encased, lead shielded inner containment. The transfer case is covered on the top and sides by a shield constructed to provide fire and impact limiting properties and on the bottom by a steel-encased transite sheet attached to the shipping skid. The outer box of the shield is a reinforced sheet metal and envelopes a 45 mm thick layer of cedar lined by a sheet of 12.7 mm plywood. A nominal 12.7 mm air gap separates the plywood from a blanket of 12.7 mm refractory material which is bonded to a sheet metal box that forms the inside surface of the fireshield. An illustration of the package is shown on attached Drawing No. F-147 (Issue 21).

Any modification to the package design must be submitted to the CNSC for approval prior to implementation.





The configuration of the package is as follows:

Shape:	<b>Rectangular</b>	Shielding:	<b>Lead</b>
Mass:	<b>1930 kg</b>	Outer Casing:	<b>Steel</b>
Length:	<b>1010 mm</b>	Height:	<b>1156 mm</b>
Width:	<b>873 mm</b>	Diameter:	<b>n/a</b>

## **AUTHORIZED RADIOACTIVE CONTENTS**

This package is authorized to contain not more than:

- 555 TBq (15,000 Ci) of cobalt-60 metal, doubly encapsulated in C-146 and C-151 welded type 316L stainless steel capsules or in capsules of a similar design that are special form radioactive material. The decay heat output from this material shall not be greater than 231 W; or
- not more than 296 TBq (8000 Ci) of cesium-137 as cesium chloride doubly encapsulated within C-161 welded stainless steel capsules, Type 1 to 8. The decay heat output from this material shall not be greater than 42 W.

## **QUALITY ASSURANCE**

Quality assurance for the design, manufacture, testing, documentation, use, maintenance and inspection of the package shall be in accordance with:

- Best Theratronics Procedure No. IN/IM 2548 F000 (Rev. G), "Transport Package Maintenance Overview Procedure"
- Packaging and Transport of Nuclear Substances Regulations, 2015
- IAEA Regulations for the Safe Transport of Radioactive Material, 2012 Edition

## **SHIPMENT**

The preparation for shipment of the package shall be in accordance with:

- Best Theratronics Procedure No. IN/PP 1522 F147 (Rev. E), "Preparation for Shipment for the F-147 Type B(U) Radioactive Material Transport Package"
- Packaging and Transport of Nuclear Substances Regulations, 2015
- IAEA Regulations for the Safe Transport of Radioactive Material, 2012 Edition

The average surface heat flux of this package with 555 TBq of cobalt-60 is 46 W/m<sup>2</sup>. For heat fluxes exceeding 15 W/m<sup>2</sup> supplementary arrangements must be made with the carrier to ensure adequate heat dissipation.



Canada's Nuclear Regulator  
L'organisme de réglementation  
nucléaire du Canada

Canadian Certificate No.: **CDN/2009/B(U) (Rev. 15)**

Issue Date: **Sep-27-2018**

Expiry Date: **Nov-30-2022**

CNSC File: **30-A2-89-0**

This certificate does not relieve the consignor from compliance with any requirement of the government of any country through or into which the package will be transported.

A handwritten signature in black ink, appearing to read 'R. Garg'.

---

R. Garg  
Designated Officer pursuant to paragraph 37(2)(a)  
of the Nuclear Safety and Control Act





Canada's Nuclear Regulator  
L'organisme de réglementation  
nucléaire du Canada

## NOTES

Revision 14: November 13, 2014. Certificate renewed.

Revision 15: September 27, 2018. Certificate renewed.



Canadian Nuclear  
Safety Commission

Commission canadienne  
de sûreté nucléaire

Canada

**Parts List**

1. Lifting handles
2. Source drawer
3. Dummy drawer
4. Door screws: 5/8-11 x 1 in. LG socket head (16)
5. Neoprene gasket (2)
6. Lead wire seal (2)
7. Radiation caution plate (3): on two opposite sides of overpack and one on base of transfer case
8. Shipping container identification label (3): on two opposite sides of overpack and one on base of transfer case
9. Spare dummy drawer
10. Transite: 1.27 cm (0.5 in.) steel encased
11. Fireshield: outer - steel frame and box  
inner - cedar, plywood, kaowool, steel box
12. Lead shielded door (2)
13. Lead shielding, steel encased
14. Fireshield bolt, washer, nut 1/2-13 x 2.5 in. LG hex hd (20)
15. Radioactive category label (2): on two opposite sides
16. Fireshield lifting handles with cover plates installed
17. Lead wire seal (1)
18. Drawer locator pin (2)
19. Drawer stop pin (2)
20. UN number label (2): on two opposite sides, next to radioactive category labels

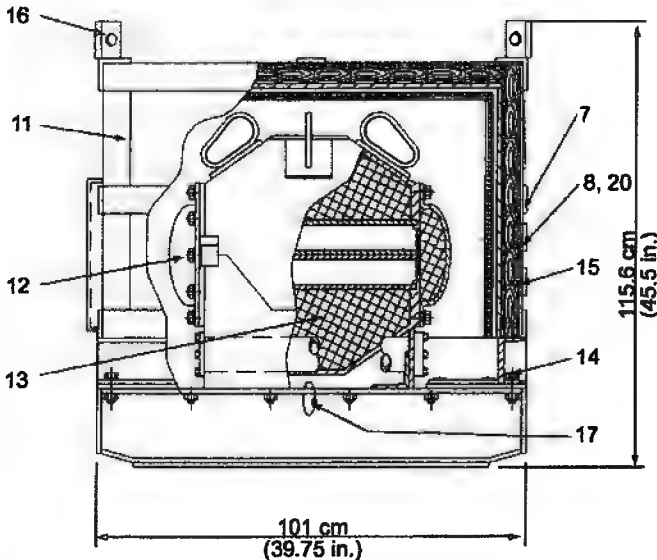
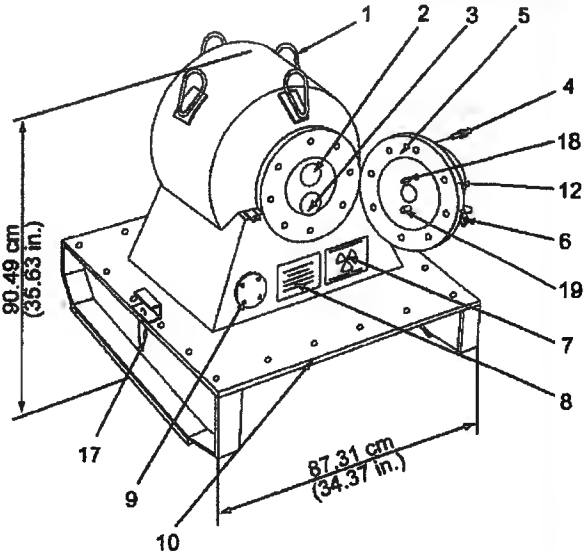

**Notes**

1. CNSC certification CDN/2009/B(U)
2. Conforms to IAEA Type B(U)
3. Lead shielding 22.9 cm (9 in.)
4. Projected floor loading: 2181 kg/m<sup>2</sup> (449 lb/ft<sup>2</sup>)
5. Approved contents:  
15,000 curies cobalt-60  
8,000 curies cesium-137
6. Total weight - 1,930 kg (4,260 lb.)
7. WARNING  
Cover plates must be in place on the lifting handles on the fireshield to prevent their use for lifting or tie-down during transit. The package should be lifted by platform truck or fork lift truck.
8. Reference Drawings:  
Packaging serial numbers 1-60: TC-3-17/D93-V-46

JUL 28 2010

**Best<sup>®</sup>**  
**Theratronics**

413 March Road  
Ottawa, Ontario  
Canada, K2K 0E4  
Tel: (613) 591-2100

TITLE  
**Standard Round Drawer Transfer Case with Fireshield**

REF. TC-3-17/D93-V-46      REVISED Jul 10      DC 30486

DATE July 1967	No. <b>F-147</b>	ISSUE
DRAWN [Signature]	APPROVED [Signature]	<b>21</b>
SHEET 1 OF 1		

THIS DRAWING IS THE PROPERTY OF BEST THERATRONICS LTD. AND IS SUBMITTED FOR CONSIDERATION ON THE UNDERSTANDING THAT THERE SHALL BE NO EXPLOITATION OF ANY INFORMATION CONTAINED HEREIN EXCEPT WITH THE SPECIFIC WRITTEN AGREEMENT OF BEST THERATRONICS LTD.



U.S. Department of  
Transportation

**Pipeline and  
Hazardous Materials  
Safety Administration**

East Building, PHH-23  
1200 New Jersey Ave, SE  
Washington, D.C. 20590

**CERTIFICATE NUMBER:** USA/6355/B(U)-85

**ORIGINAL REGISTRANT(S) :**

Source Production and Equipment Company, Inc.  
113 Teal Street  
St. Rose, LA, 70087  
USA

Best Theratronics Ltd.  
413 March Road  
Ottawa, Ontario, K2K 0E4  
Canada

Nordion (Canada) Inc.  
447 March Road  
Ottawa, Ontario, K2K 1X8  
Canada